

Little Toys

Written by Arvind Gupta
(Email arvindguptatoys@hotmail.com)

Illustrations by Avinash Deshpande

**Publisher: National Book Trust, A-5 Green Park, New Delhi 110016, India
(Rupees Twenty)**

Introduction

It is an irony of modern consumerism that junk products are packed in tough cartons. While the frail human body consumes and digests the junk, it is the environment that has to grapple and reckon with the tough, non-biodegradable waste. And, in the process, humans become sick and the environment decays. Today we can see city parks littered and garbage dumps overflowing with tetra packs-- empty cartons of *Frooti*, *Tree Top*, *Jumping Jack* or *Dhara*. These packets are made with layers of different materials -- plastic, aluminum and paper -- all fused into one multi-walled laminate. We know that aluminum does not rust and plastics do not rot. These materials are energy-intensive and take a heavy toll of the environment, which helplessly chokes under the debris. An attempt has been made in the book to show how some of this modern junk can be recycled into joyous toys. Film-roll cases can be transformed into a high-efficiency pump, *Frooti* tetra packs into measuring cylinders or butterflies, packets of cigarette into merry-go-rounds. These new raw materials offer innumerable possibilities for use in low-cost science experiments and in making dynamic toys. For five years children in *Mirambika* School made and tested these toys. Several of these toys have been serialized in the magazine *Science Reporter*. I thank CAPART for the fellowship they gave which enabled me to collate these toys into a book.

ARVIND GUPTA

WHIRLING WOOL

When you blow through this toy, a loop of wool swirls round and round.

All you require to make this toy is a bit of wool, a piece of cello-tape and a throwaway plastic soda-straw!

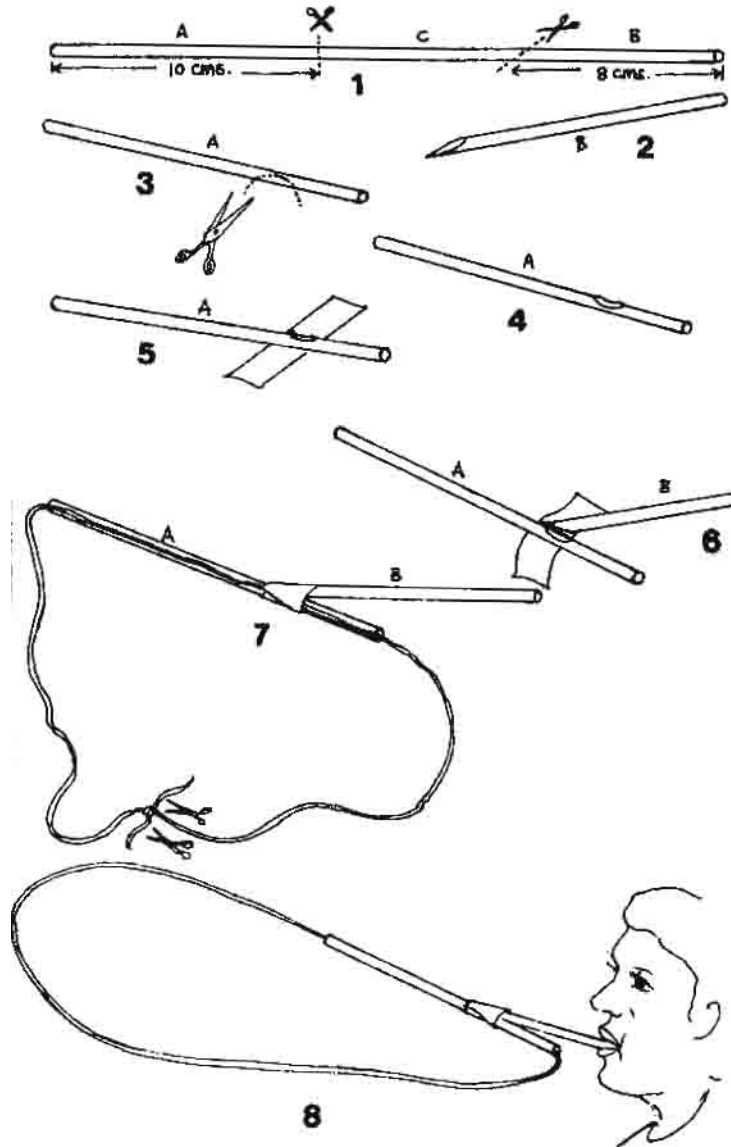

Take a 5-mm thick soda-straw.

The thin ones do not work very well.

Cut a 10-cm long piece A from one end.

From the other end cut an 8-cm long piece at a sharp angle.

Discard the middle portion C (Fig 1).

Straw "B" should look like an inverted pen-nib (Fig 2).

Press straw "A" at about 3-cm from one end so as to flatten it before cutting an arc (Fig 3).

There will now be an elliptical hole about 7-8-mm long on straw "A" as shown (Fig 4).

Paste a 2-cm long cello-tape just beneath the hole in straw "A" (Fig 5).

Cover the hole with straw "B" and wrap the cello-tape on it (Fig 6).

Make sure that the nib point of straw "B" does not enter the elliptical hole of straw "A".

Weave 80-90-cm long piece of thin wool through straw "A".

Tie the ends of the wool in a tight knot and closely trim the ends.

If you now blow hard through straw "B" you will find to your utter delight that the whole loop of wool rotates (Fig 8).

The complete toy takes less than five minutes to make.

Why does the loop of wool rotate?

Well, wool is like a very fibrous thread.

Straw "A" is like a tube with a fibrous thread inside it.

Because of the acute angle at which the straws are attached, on blowing, most of the air goes through the long end of straw "A".

In the process air pushes the fibers through the tube.

The up thrust makes the whole loop rotate round and round. It is great fun to be able to make this beautiful toy at less than 25 paise!

BELLOWS PUMP

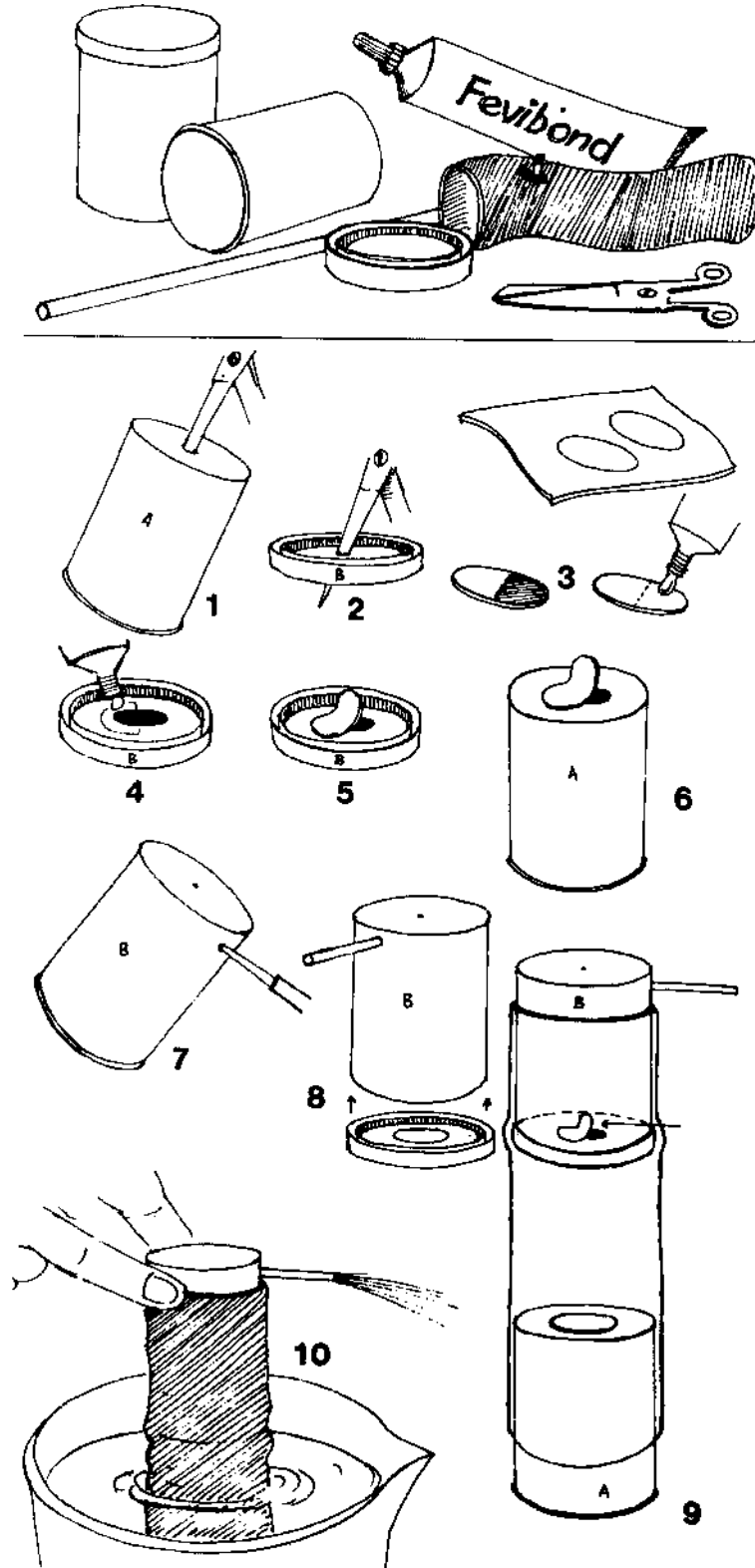

This very efficient pump is quite easy to make. It requires two film-roll plastic cases, 15-cm of old cycle tube, an old refill or a short thick straw (like the one found in tetra packs of fruit juices) and a rubber-based adhesive like *Fevibond* or *Vamicol*.

Make a hole in the base of film-roll case "A" by using a divider point.

Widen this hole by gently rotating the pointed end of the scissors.

The hole should be about 1-cm in diameter and should not have any burrs or protrusions (Fig 1).

Make a similar hole in cap "B" (Fig 2).

Cut two circular washers about 1.5-cm in diameter from a cycle rubber-tube.

Apply *Fevibond* on half of the area of the two washers (Fig 3) and on the cap (Fig 4) paste the washer.

The washer which is stuck only on one side, will act like a hinge.

It will open and close like a valve.

This is the delivery valve (Fig 5).

Paste the other valve on the base of the film-roll case.

This is the suction valve (Fig 6).

Take another film-roll case "B" and make a small hole on its cylindrical surface (Fig 7).

Press fit a short thick straw or a ball-pen refill in it for the delivery pipe (Fig 8).

Fix the cap with the delivery valve (Fig 5) to case "B" as shown in Fig 8.

Cut a length of 15-cm from an old cycle tube. Stretch and slide the tube over both the cases as shown in Fig 9.

The cases should be separated by about 8-cm of cycle tube.

This rubber tube acts like a pair of bellows.

Now hold the lower case "A" in water and press the top case "B" downwards.

After a few initial strokes water starts gushing out of the delivery tube (Fig 10).

PICHKARI

The bellows pump can be converted into a *Pichkari*- to pump and sprinkle colored water during the festival of *Holi*.

Take the cap of the film-roll case and make a hole in its center.

Press fit a thick, long soda-straw or tube in this hole. Fit the cap to the lower case (Fig 1).

Now place the pump on a bottle filled with water and start pumping. After a few strokes the pump will get primed.

Then with every down-ward stroke 20-ml of water will spurt out of the delivery pipe.

Instead of just pressing down the top bottle you can give it a downward twist (Fig 2).

This squeezing action will squirt the water in an arc, similar to what is seen in a sprinkler.

The bellows pump is based on a chance discovery that two film-roll cases can fit snugly at the two ends of a cycle tube.

The portion of the tube between the cases acts like a pair of bellows.

How does the pump work?

Suppose the top case were to be pressed down with the bellows in the squeezed position.

On releasing pressure the rubber tube returns to its original shape, thus creating a partial vacuum.

This opens the suction valve, allowing water to enter from the reservoir into the rubber bellows.

On pressing the bellows downwards the suction valve closes but the delivery valve opens and allows water to gush out from the delivery pipe.

This pump is remarkably efficient.

The hinged rubber washer acts as very worthy flap valve. It opens and closes like a fish's mouth.

With this pump, a balloon can be filled not only with water but also with air.

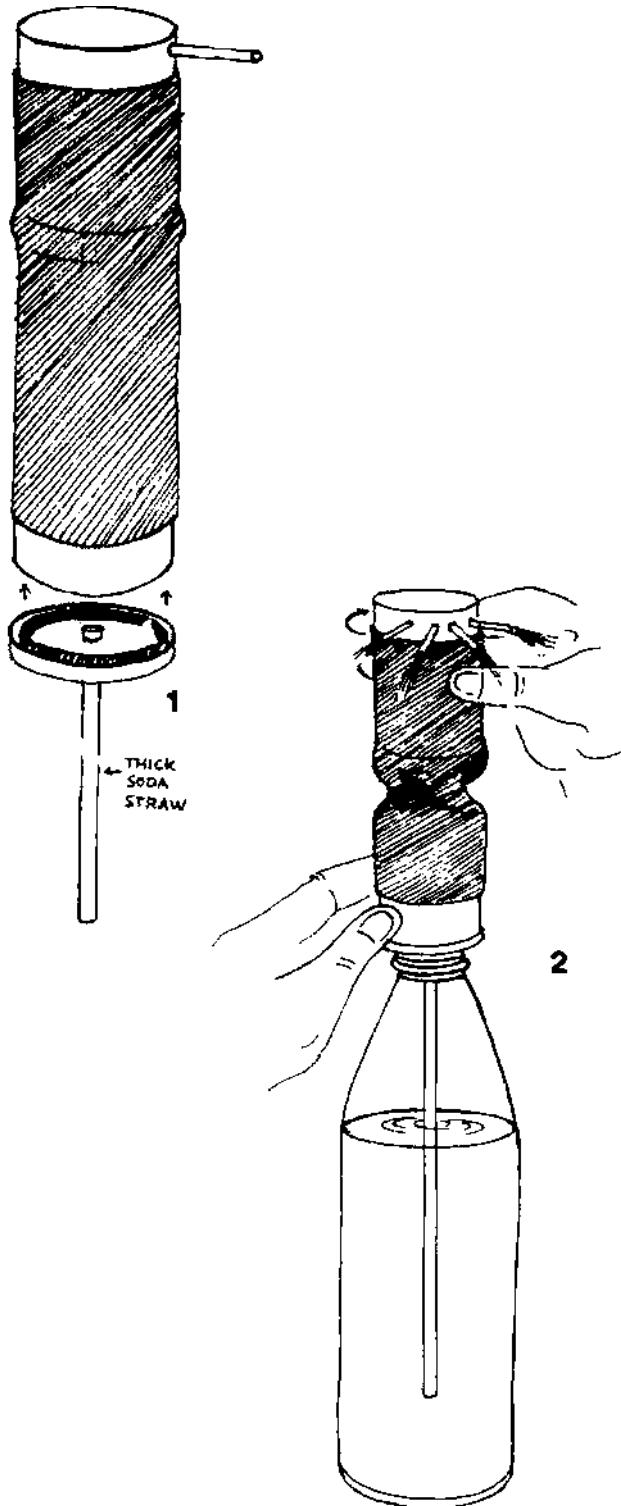

MUSICAL BALLOON

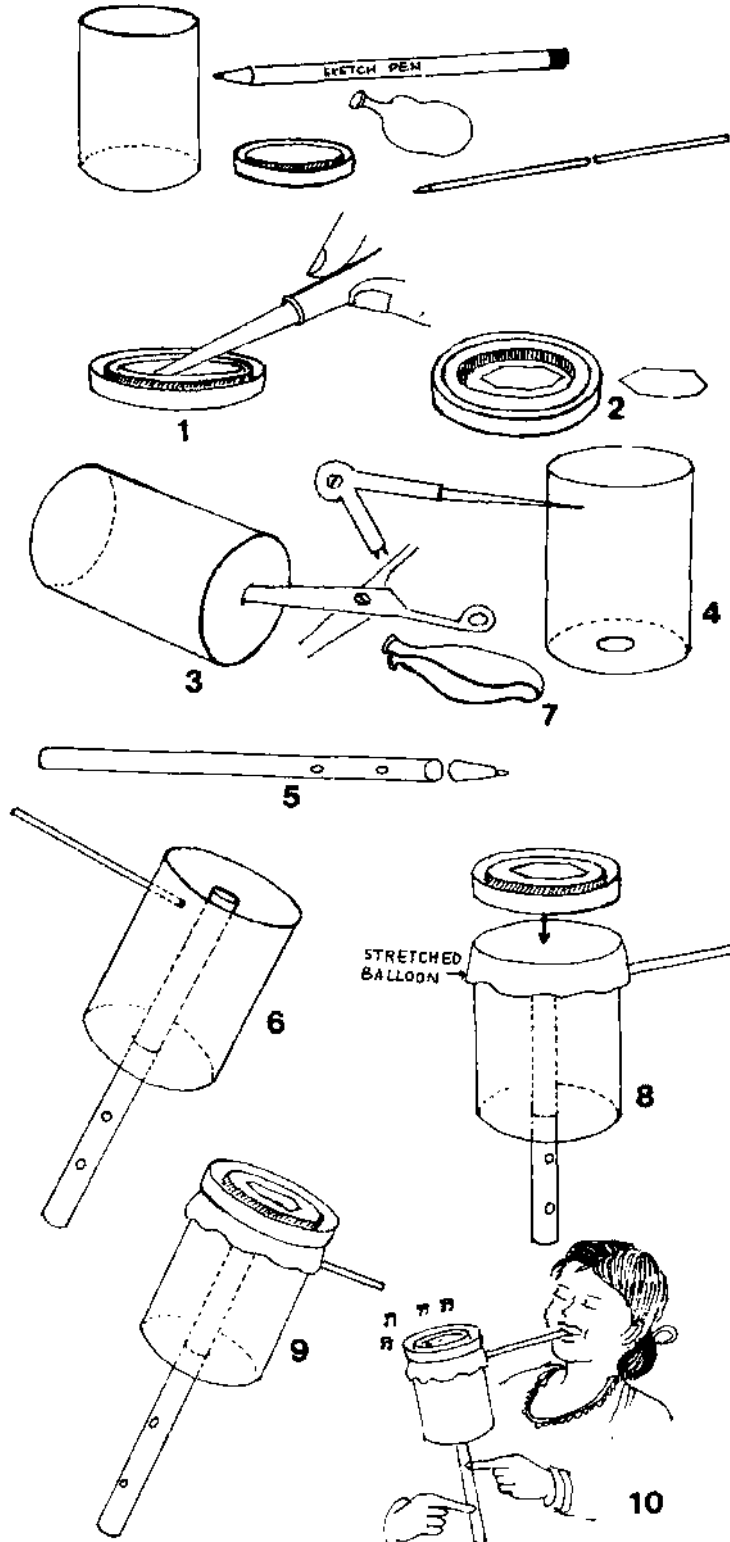

This musical instrument, which produces melodious notes, reminds one of the snake charmer's musical instrument – the *been*. For making it you will need a film-roll case, a sketch pen, an empty ball-pen refill, a torn balloon and some ordinary hand- tools.

Cut the middle portion of the cap of the film-roll case with a sharp knife (Fig 1).

The hole should be about 1.5-cm in diameter. Its shape is not important (Fig 2).

Make a hole in the middle of the base of the case.

Use pointed scissors to widen this hole (Fig 3). The hole should be just large enough to squeeze a sketch pen through it.

Make a small hole on the cylindrical surface of the case about 1-cm from the open end by using a divider point (Fig 4).

This hole should be just big enough to enable a ball-pen refill to fit into it.

Take the sketch pen and snip off its pointed end. Make two small holes at a distance of 1-cm and 3-cm from this end (Fig 5).

Press fit the sketch pen and ball-pen refill in the film-roll case (Fig 6).

Cut a balloon as shown (Fig 7).

Stretch the balloon on the mouth of the case. Replace the cap on the case to keep the stretched balloon in place (Fig 8).

The complete assembly of the musical instrument is shown (Fig 9).

Now gently slide the sketch pen upwards so that it just touches the stretched balloon.

Simultaneously, blow through the refill (Fig 10).

At one particular position of the sketch pen, you will hear a clear and loud musical note. Fix the sketch pen in this position and keep blowing.

By opening and closing the holes, as in the case of a flute, you can play a few notes.

The balloon acts like a stretched membrane or diaphragm and begins to vibrate when you blow in.

The plastic case acts like a sound box.

CRANKY DOLL

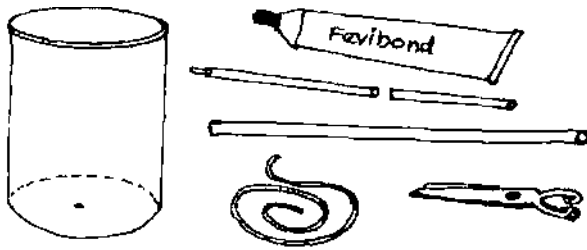

As you rotate the handle of this little machine, the doll on top jumps up and down. This cranky doll can be easily made by using a film-roll case, a thick straw, a thin wire of length 12-cm, a refill, a card sheet, glue and some hand-tools.

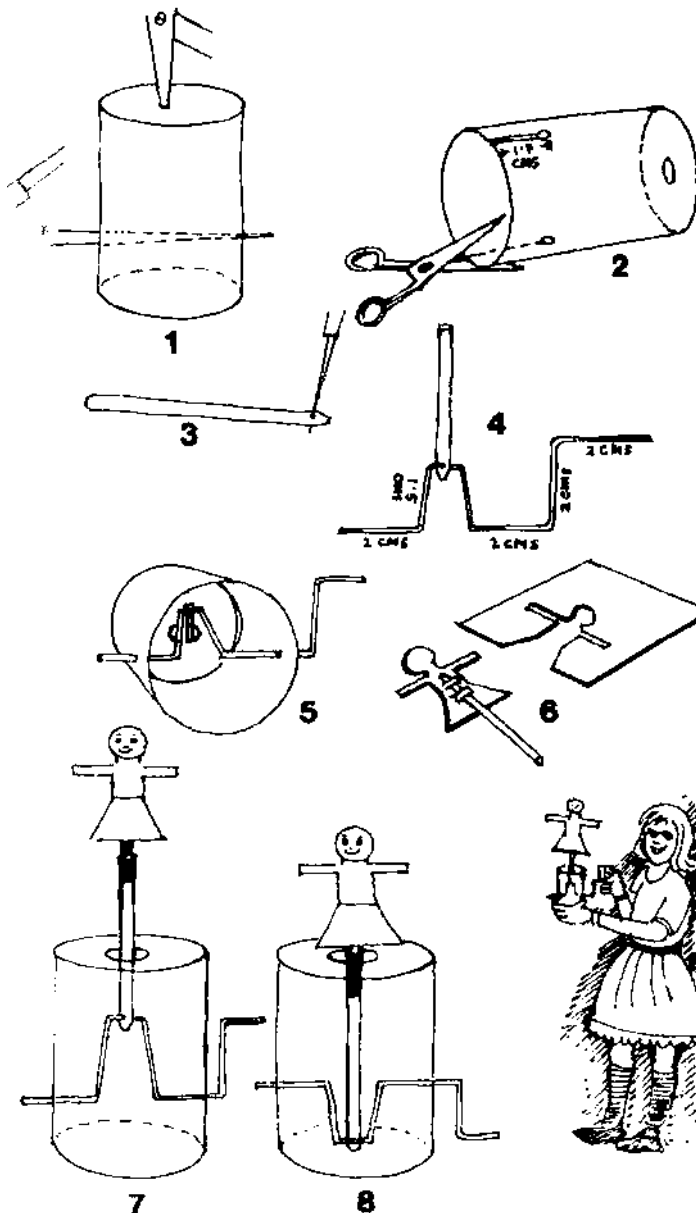

Using a divider point, make two holes in the cylindrical surface of the film-roll case, at a distance of 1.7-cm from the open end. Make an 8-mm wide hole at the center of the bottle base (Fig 1). Use scissors to make straight cuts from the mouth of the case to the holes (Fig 2).

Take a thick straw of length 5-cm and with a divider make a hole at one end. Also bevel cut the corners of this end (Fig 3). Take a thin wire of length 12-cm and bend it like a U-shaped crank and handle as shown (Fig 4). Slip the straw in the crank. Gently slip the wire crank through the cuts in the holes by pressing the mouth of the case. The straw will, out of the base hole of the case (Fig 5).

Cut the outline of a doll from a card sheet. Affix a small ball-pen refill to the doll (Fig 6). Slip this refill into the straw. Now, as you rotate the handle, the U-shaped crank moves in a circle, making the straw move up and down. The doll, which is attached to the straw, also jumps up and down.

The pistons of a car engine move up and down inside the cylinder. This makes the crankshaft go round and round. In our small machine the rotary motion of the handle gets converted into the straight-line motion of the straw. In Fig 7, the crank is in its topmost position, whereas Fig 8 shows its lowermost position.

SAIL CAR

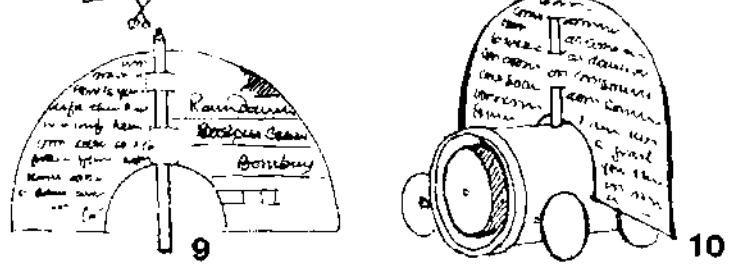
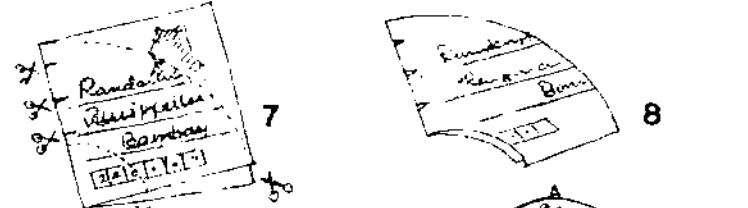
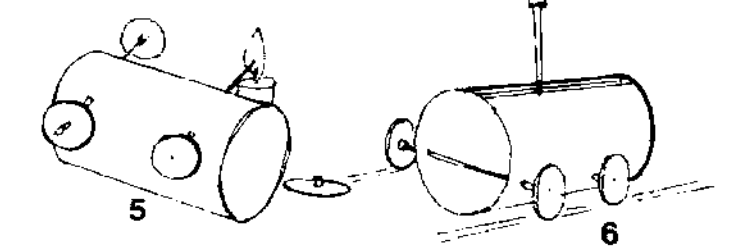
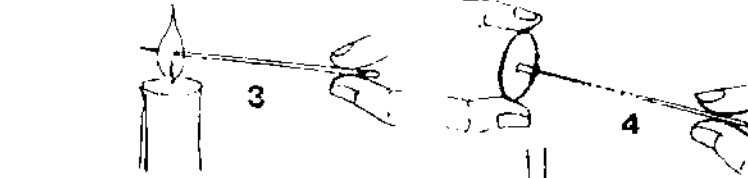
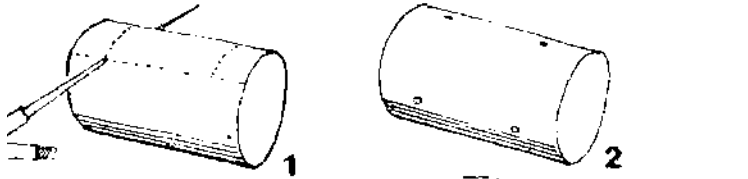
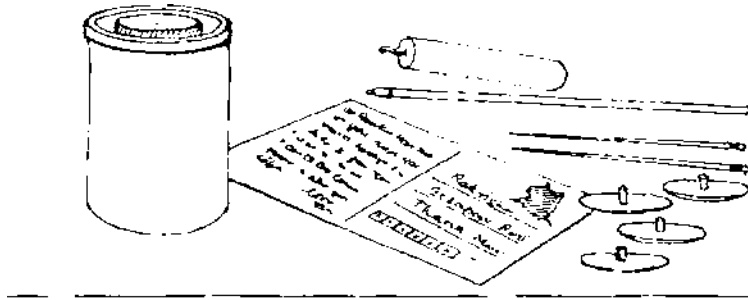

The awesome power of wind is being increasingly used in our country to produce electricity.

This little sail car also demonstrates the power of the wind.

The breeze from the ceiling fan is enough to make the car run.

First, mark out a rectangle 3.5-cm x 2-cm on a film-roll case.

Then make four holes with a divider point as shown in Fig 1.

The four holes for the two axles are shown in Fig 2. For making the wheels you need four buttons made of cheap plastic.

These buttons have a protruding plastic pip in the middle.

Take a 5-cm long needle and heat its tip (Fig 3). Insert the needle tip in the center pip of the button.

The hot needle melts the plastic and goes in (Fig 4).

Fit these one-wheel axles into the holes of the film-roll case.

Now heat the other tip of the needle and fix the second wheel (Fig 5).

Make a vertical hole through the center of the car (Fig 6).

The hole should be just big enough to accommodate a ball-pen refill into it.

Double-fold a postcard and mark the two area and slits as shown (Fig 7).

Cut the two arcs and the slits (Fig 8).

Now weave the ball-pen refill through the slits in the postcard (Fig 9).

Fix the refill along with the postcard sail in the car.

Replace the cap of the case (Fig 10).

You can tie a thin string to the car and keep it on the smooth floor under the ceiling fan.

The breeze will propel the car to one end of the room.

You can pull the string and bring the car back under the fan (Fig 11).

This joyous game can go on and on for hours.

DANCING DOLL

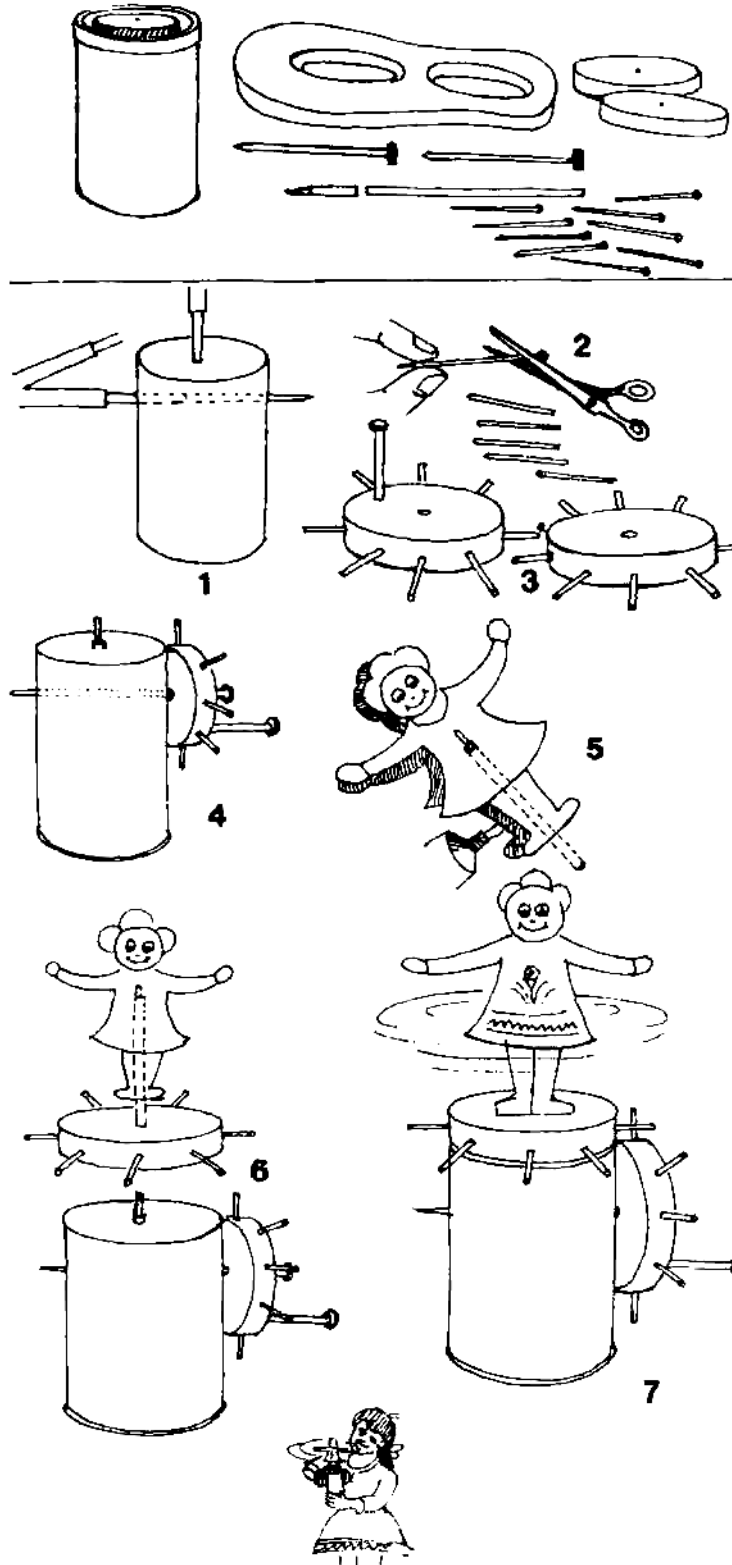

When you turn the handle of this toy, the dancing doll goes round and round.

Take a film-roll case and make a hole in its base.

This hole should be just big enough to press fit a plastic refill.

Also make a horizontal hole in the case, 1.5-cm from the base (Fig 1).

Cut two circular or octagonal discs, 3-cm in diameter, from an old slipper.

Make holes in the centers of these discs. Snip off the heads of 16 steel pins with scissors (Fig 2).

Fix eight pins equidistantly on the rim of each disc.

Fix a nail for the handle near the edge of one disc (Fig 3).

Attach a ball-pen refill to the base of the case (Fig 1). Pass a nail through the center of the disc with the handle.

Pass this nail through the holes in the case (Fig 4).

Cut a doll from a doubled-up card sheet and stick a refill through it (Fig 5).

Fix this refill into the center of the other rubber disc.

Place this doll-disc assembly on the refill attached to the base of the case (Fig 6).

On rotating the handle, the vertical gear rotates.

The pins of this vertical gear mesh with the pins of the horizontal gear, making the dancing doll go round and round (Fig 7).

The driver gear moves in the vertical plane whereas the driven gear moves in the horizontal plane.

A similar bevel gear mechanism is used in all cars and buses to transmit drive.

The propeller shaft from the engine ends in the differential.

The bevel gears inside it transmit the drive to the rear wheels, which are at right angles to the propeller shaft.

ROTATING FAN

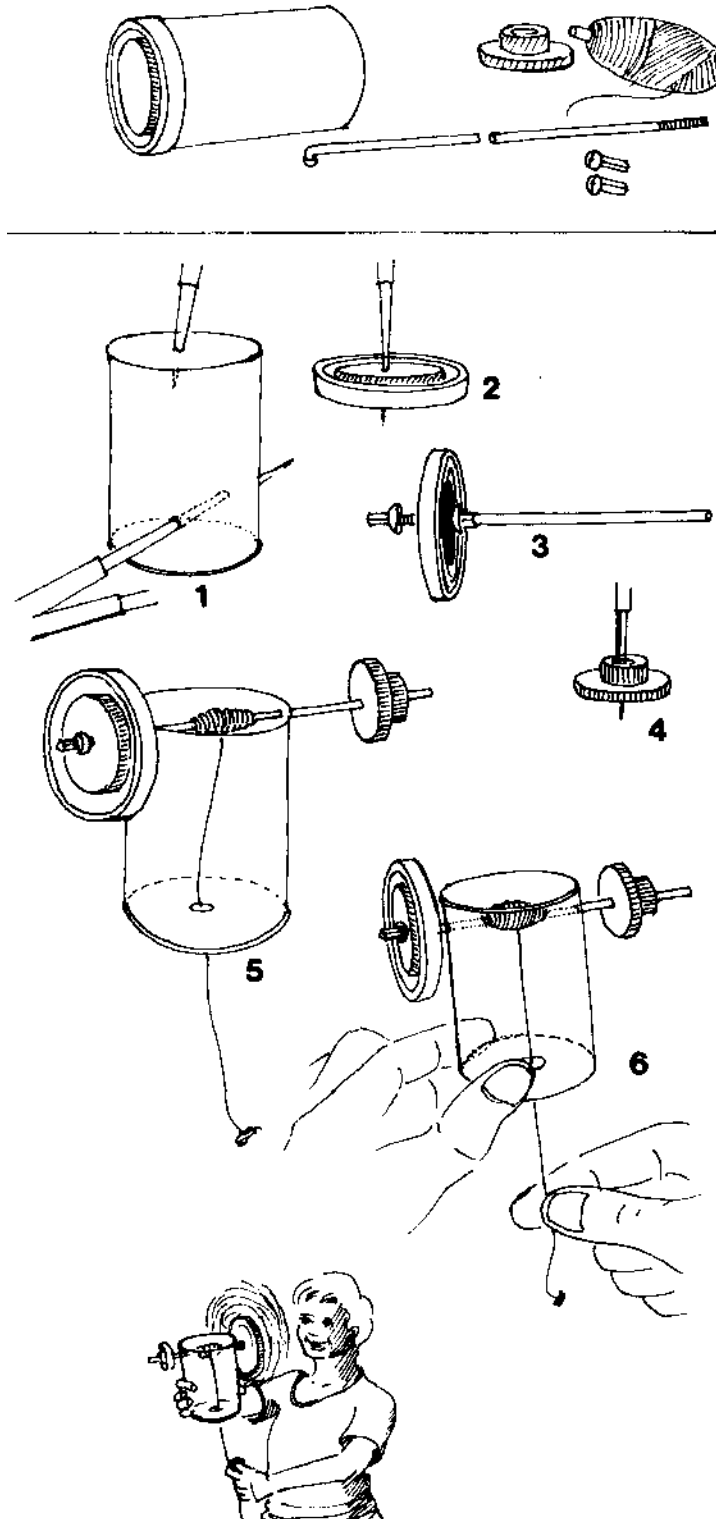

The rotating fan is based on an old traditional toy.

The materials used for making this fan are a film-roll case; a cycle spoke with two nipple nuts, a rubber cap from an injection bottle and about 50-cm of strong thread.

First make a 5-mm hole in the base center of the film-roll case.

Make two holes in the cylindrical surface of the case, about 1-cm below its open mouth (Fig 1).

Pierce a divider point through the cap center of the film-roll case (Fig 2).

Cut a 7-cm long cycle spoke.

Fix the case cap to the spoke's threaded end by tightening two nipple nuts (Fig 3).

Make a hole in the injection-bottle cap by using a divider point (Fig 4).

Place the spoke in the case holes and insert the injection-bottle rubber cap.

The rubber cap prevents the spoke from coming out of the case.

Tie one end of the 50-cm long string to the middle of the cycle spoke.

Weave the other end through the base hole of the case.

Tie a piece of rubber at the end of the string for a good grip (Fig 5).

Now rotate the fan so that the string loops around the spoke.

The toy is now ready for operation.

Pull the string downwards and then hold it loose.

The fan will spin in one direction and in the process the string gets rewound on the spoke.

On pulling the string again, the fan rotates in the opposite direction (Fig 6).

The rotating cap acts like a flywheel.

Because of this stored energy the fan tends to rotate even after the thread has unwrapped from the spoke.

In the process the string gets rewound on the spoke.

CIRCLING AIRPLANE

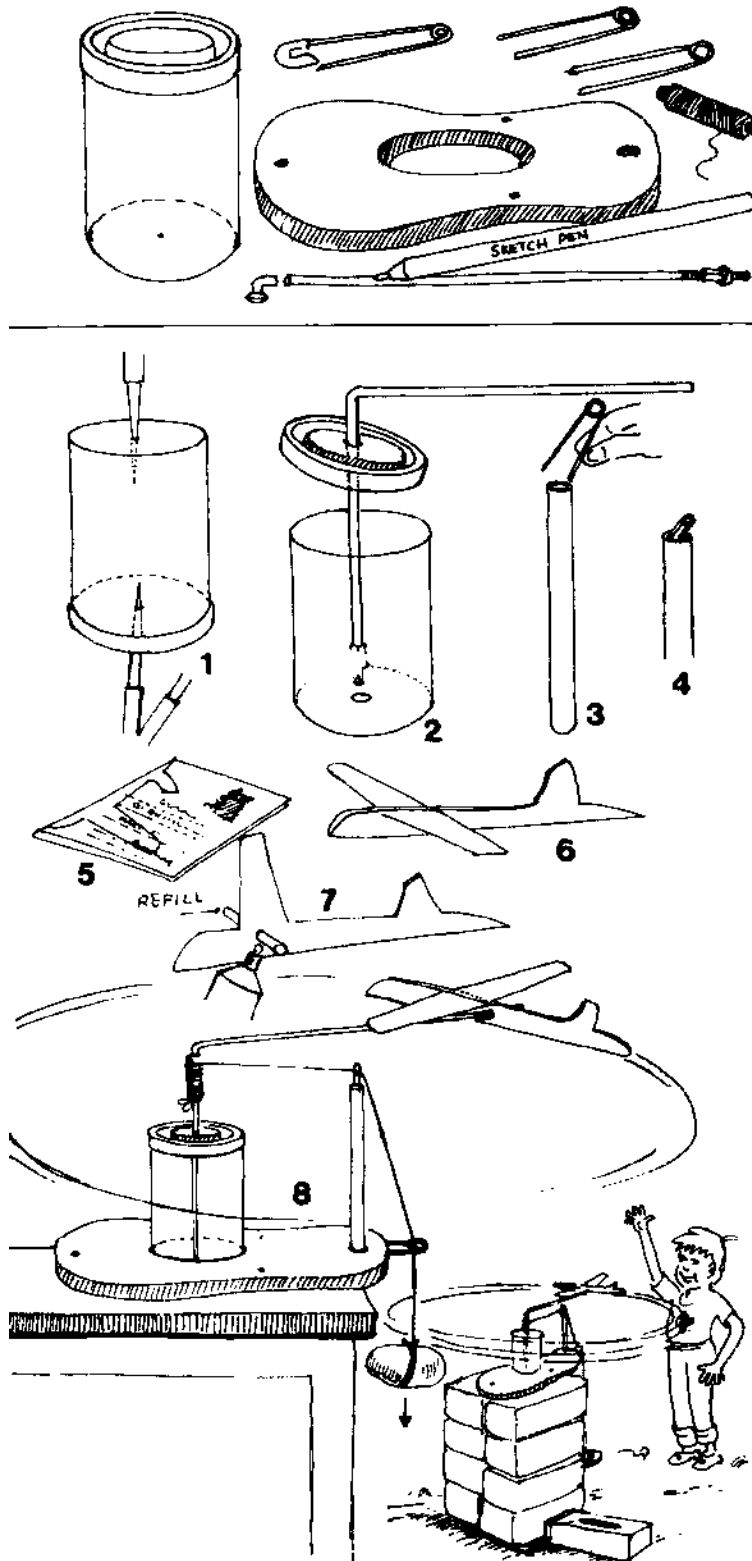

On winding this toy, a small airplane can be made to go round and round in circles.

It is based on the principle of conversion of potential energy into kinetic energy.

Make holes in the middle of the cap and the base of a film-roll case by using a divider point (Fig 1).

Bend a cycle spoke at right angles.

The vertical leg with the threads should be 9-cm long.

Once the nipple nut is tightened on the threads, it prevents the spoke from falling through the case.

The cap of the case and its base become the bearings for the rotating spoke (Fig 2).

Snip a safety pin and insert it in the body of a sketch pen (Fig 3, 4).

Mark out the outline of an airplane on a doubled-up postcard (Fig 5).

Cut this outline and shape it into an airplane (Fig 6).

Make a hole in the aircraft's body near the main wing.

Stick a 2-cm long refill in this hole with some adhesive (Fig 7).

Make a hole in an old rubber slipper so that the film-roll case can be press fitted into it.

Make another small hole in the slipper to press fit the sketch pen.

Fix the airplane to the spoke.

Tie a 25-cm long string to the cycle spoke.

Weave it through the eyelets of the two safety pins as shown (Fig 8).

Tie a small stone at the other end of the string.

On rotating the airplane by hand, the string gets wound on the spoke and the stone is raised up.

If the toy is now kept on the table, the stone descends slowly, thus rotating the vertical spoke.

This will make the airplane go round and round in circles, to the utter delight of your friends!

FROOTI FACTS

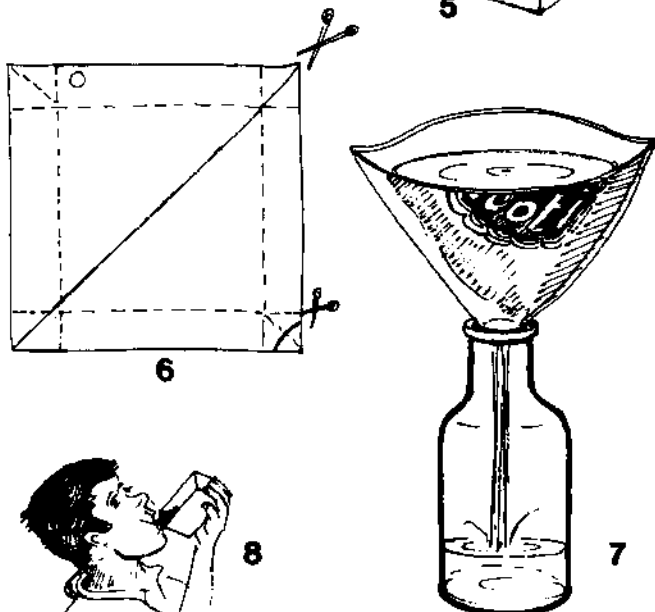
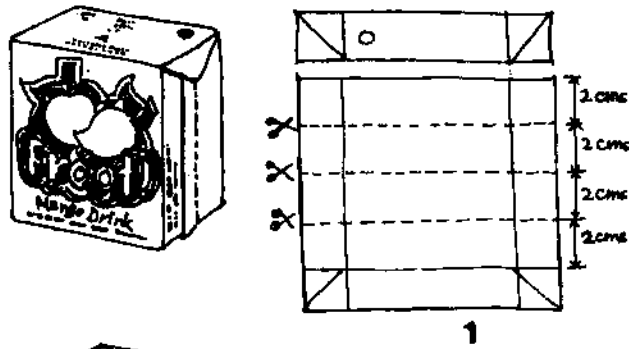

The *Frooti* carton is called a tetra pack. Tetra packs are made by fusing together layers of different materials like plastic, aluminum, paper, etc, into a single composite sheet. This wonder packaging material apart from being inexpensive is also energy-intensive. Being non-biodegradable, tetra packs are very difficult to recycle.

Nothing illustrates it better than the *Frooti* packet. The *Frooti* packet costs Rupees Ten. The empty *Frooti* carton costs Rupees Two - perhaps more than the drink itself!

The dimensions of the *Frooti* packet are length 6.2-cm, breadth 4.0-cm, and height 8.0-cm. The area of cross-section of the *Frooti* packet is 6.2-cm x 4.0-cm (length x breadth), which approximates to 25sq-cm. Its height is 8-cm.

Flatten out the *Frooti* pack and cut off its top lid (Fig 1).

Reshape it again into an open container with a capacity of 200-ml (Fig 2).

A height of 6-cm will make a 150-ml container (Fig 3). If the *Frooti* packet is cut in the middle, its height becomes 4.0-cm and it can hold 100-ml of any liquid (Fig 4).

Finally a 2-cm tall container will hold 50-ml (Fig 5).

As *Frooti* packets are waterproof, they can be used to approximate volumes of 200-ml, 150-ml, 100-ml, and 50-ml.

A useful funnel can be instantly made out of a *Frooti* packet.

Flatten a *Frooti* packet and cut it along the diagonal and also on two corners facing each other (Fig 6).

The *Frooti* funnel is very handy for pouring out oil and other liquids (Fig 7).

The open *Frooti* box can be used as a collapsible tumbler for drinking water during a journey (Fig 8).

Later it can be flattened and tucked away in your pocket.

FLAPPING BUTTERFLY

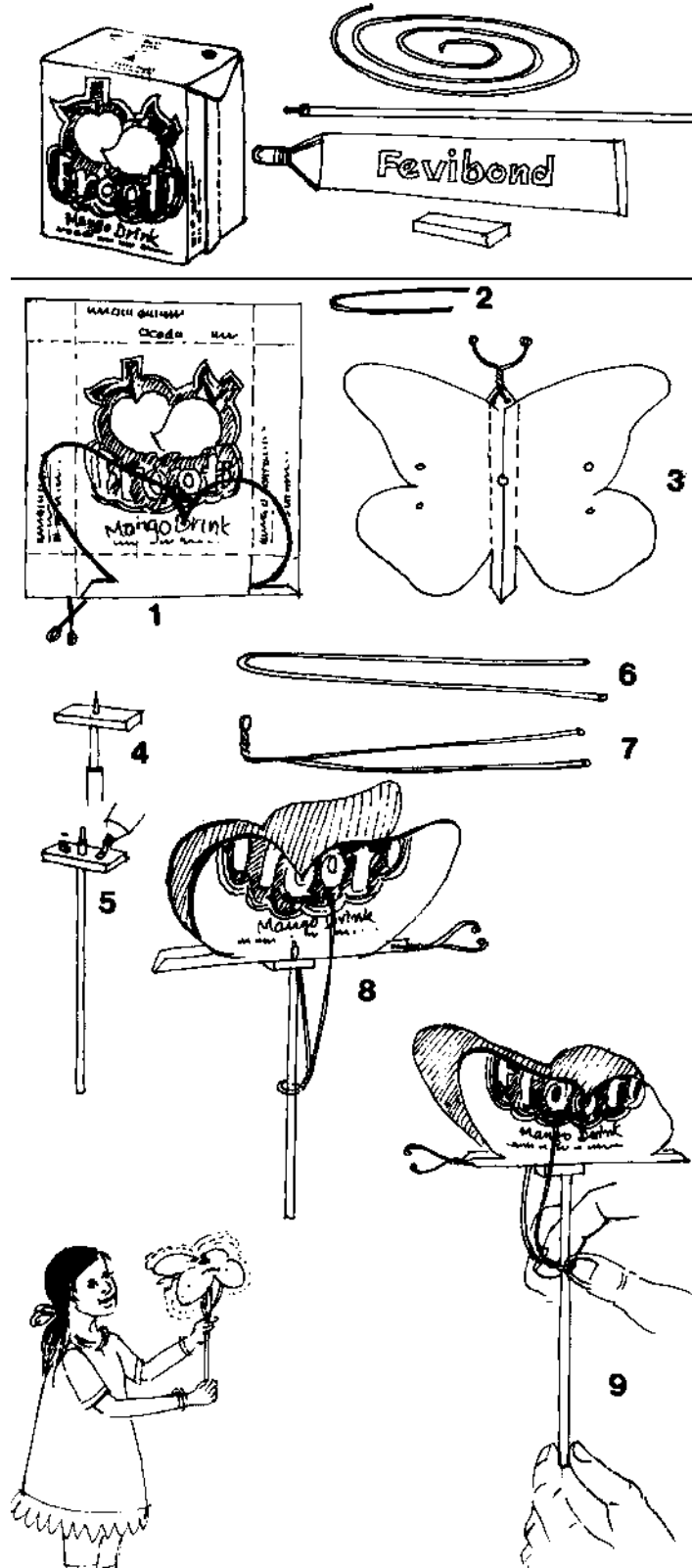

Robert Race - British toy-maker first showed this toy to me a. I have tried making it with tetra packs and other junk material.

First, flatten out a tetra pack and then mark out the butterfly on it (Fig 1).

Cut the butterfly and fold its wings on the dotted lines.

Make five holes by using a divider point - one on the midrib and two pairs near the wings.

Make two more holes near the head for the antennae.

Pass a 10-cm long V-shaped wire through these holes (Fig 2).

Twist the wires together to make the butterfly's antennae (Fig 3).

Take a thin piece of rubber and make a hole in it (Fig 4).

Press fit a long ball-pen refill in the rubber.

Apply *Fevibond* on the rubber (Fig 5).

Bend a thin wire of length 22-cm into a V-shape (Fig G).

Make a loop at the bend as shown in Fig 7.

First insert the refill in the mid-rib hole of the butterfly and then stick the rubber to the underside of the butterfly.

Weave the wire loop through the refill and pass each wire end through the two holes in the wings.

The wire ends are bent and pressed to hold them in place.

The butterfly is now ready for napping its wings (Fig 8).

Hold the refill with one hand and slide the wire loop up and down with the other.

The butterfly will flap its wings majestically (Fig 9).

If a tetra pack is not available then any thick card-sheet can be used.

By using the tetra pack this non-biodegradable waste can be recycled.

In the process, not only can you make a lovely toy but also help keep the environment clean.

CLIMBING BUTTERFLY

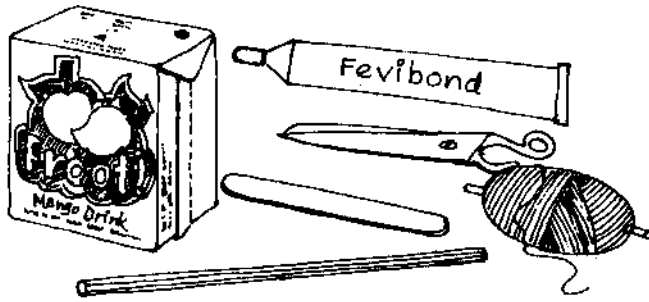

As you alternately pull the two strings of this butterfly, it surprisingly climbs up. As soon as you release the tension on the strings, the butterfly slides down.

Make three pairs of small notches on an ice-cream stick as shown in the Figure.

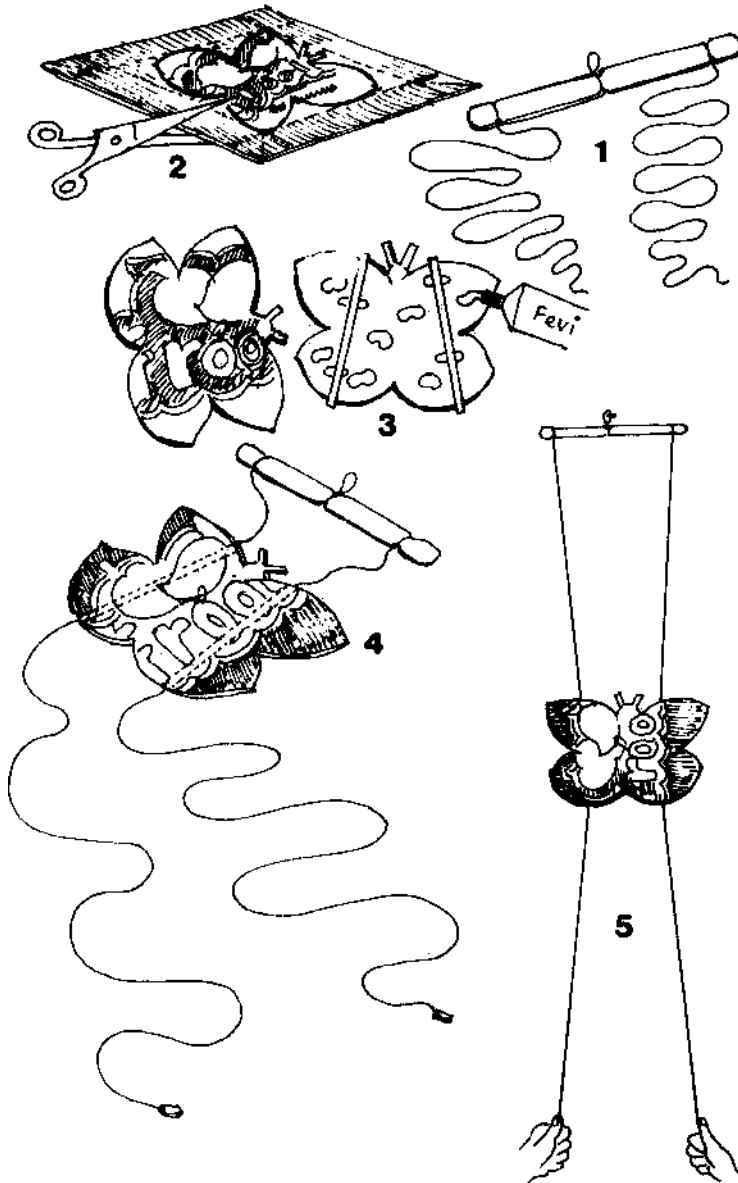

Tie two strings of length 90-cm at the two ends and a small loop of thread in the middle notch of the ice-cream stick (Fig 1).

First flatten a tetra pack and then mark out a butterfly on its middle rectangular portion.

Cut along the outline of the butterfly (Fig 2). You will get two similar butterflies each having silver inside and colored outside. Cut a thick straw in half.

Glue the two straws on the silver side of one butterfly with *Fevibond* as shown in Fig 3. The straws should not be parallel. When stuck they should be slightly tapering - narrow at the top and slightly broad at the base.

Now glue the second butterfly on to the first. Weave the threads through the side where the two ends of the straws are closer. Tie two small handles at the end of the strings (Fig 4).

Hang the middle loop on the ice-cream stick by a nail.

Now as you pull the strings alternately, the butterfly climbs upwards (Fig 5).

On releasing the tension in the strings, the butterfly slides down.

This most enjoyable toy is based on the scientific principle of friction and gravity.

NEWTON'S DISC

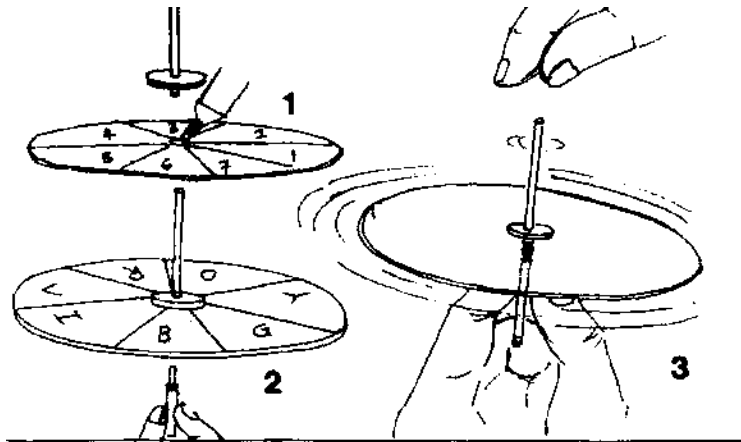

Cut a circular disc of diameter 6-cm from a tetra pack. Insert an empty ball-pen refill in a rubber washer. Fix the rubber washer in the center of the disc (Fig 1). Stick a piece of paper with the seven colors of the spectrum - VIBGYOR, painted on this disc. Pivot the disc on the brass tip of an ordinary ball-pen refill (Fig 2). Spin the disc with the top of the refill and see all the seven colors combine to look grayish-white (Fig 3). The plastic refill, on its own brass tip, makes for a very smooth bearing.

ROLLING DOWN THE RAMP

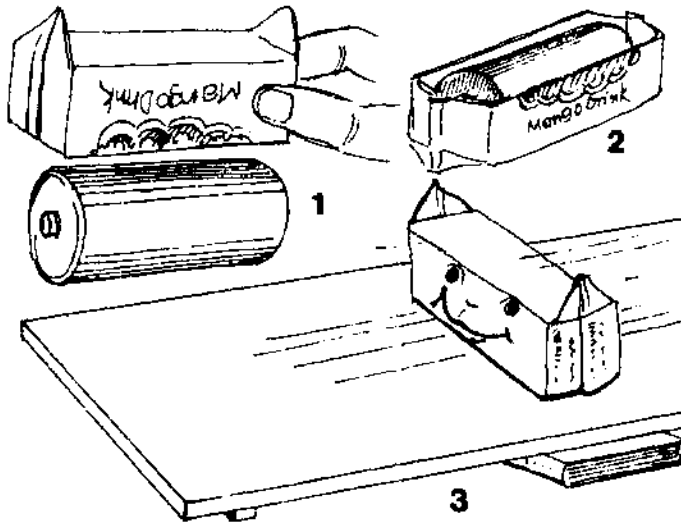

Cut a tetra pack so that it is 3-cm high. Put an ordinary used battery inside this box (Fig 1).

The height of the box should be 2-3 mm less than the diameter of the battery cell (Fig 2).

On placing this assembly on a slight incline, it rolls down the ramp (Fig 3).

You can draw a face on the box to make it more attractive.

TREE NAMEPLATES

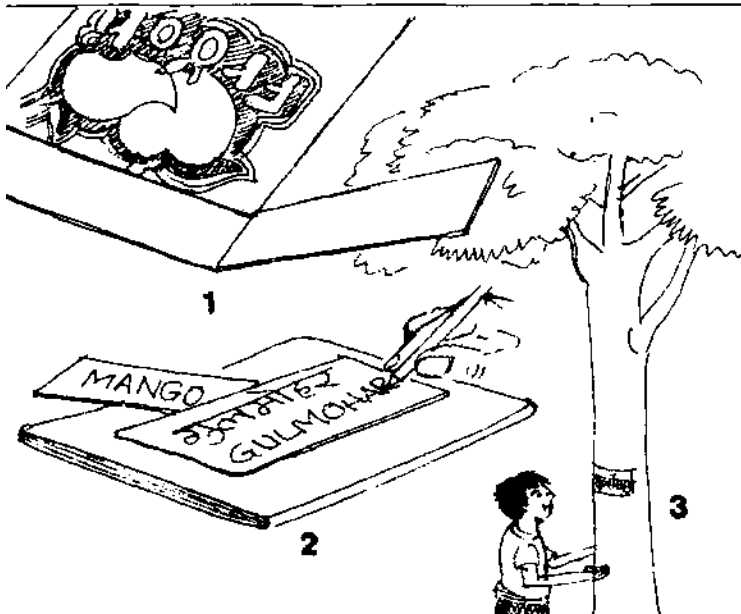

Cut a 4-cm x 6-cm strip from a tetra pack (Fig 1).

Place it on an old magazine with its silver side up.

With a ball-pen write the name of a tree on this strip (Fig 2).

Press hard the ball-pen to get a good and clear impression.

These name-plates can be pinned to the tree with a small shoe-tack nail (Fig 3).

Since the inside of a tetra pack is made of laminated aluminum foil, the waterproof nameplates can last long and be used for educating the common man about the names of roadside trees.

LEHAR LAFANGA

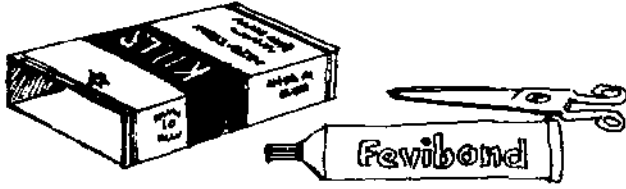

Sri Lal Kishan, a science teacher from Bhiwani, Haryana, designed this simple toy.

One day while he was playing with the outer shell of a cigarette packet, its rectangular cavity changed shape and became a parallelogram.

It was this chance discovery, which led him to design this ingenious toy.

Cut the corner edges of a cigarette packet halfway through and fold the cut flaps at right angles.

Draw a human profile- the face, hands and legs on the flaps -- and cut them (Fig 1).

The rectangular cavity in the pack will form the body of the Figure as shown in Fig 2.

On pressing the cigarette packet (Fig 3), its rectangular cavity changes into a parallelogram, causing the cartoon character to bob its head and move its hands and legs in an unusual manner.

One can draw and cut out separately the head, hands and legs of the comic character *Fido Dido*, the famous Lehar Lafanga (Fig 5).

These pieces can be stuck on the small flaps of the cigarette packet (Fig 4).

On pressing the cigarette packet, the head, hands and legs move in a funny way -- to the sheer pleasure of onlookers (Fig 6).

This is a good way to make simple puppets.

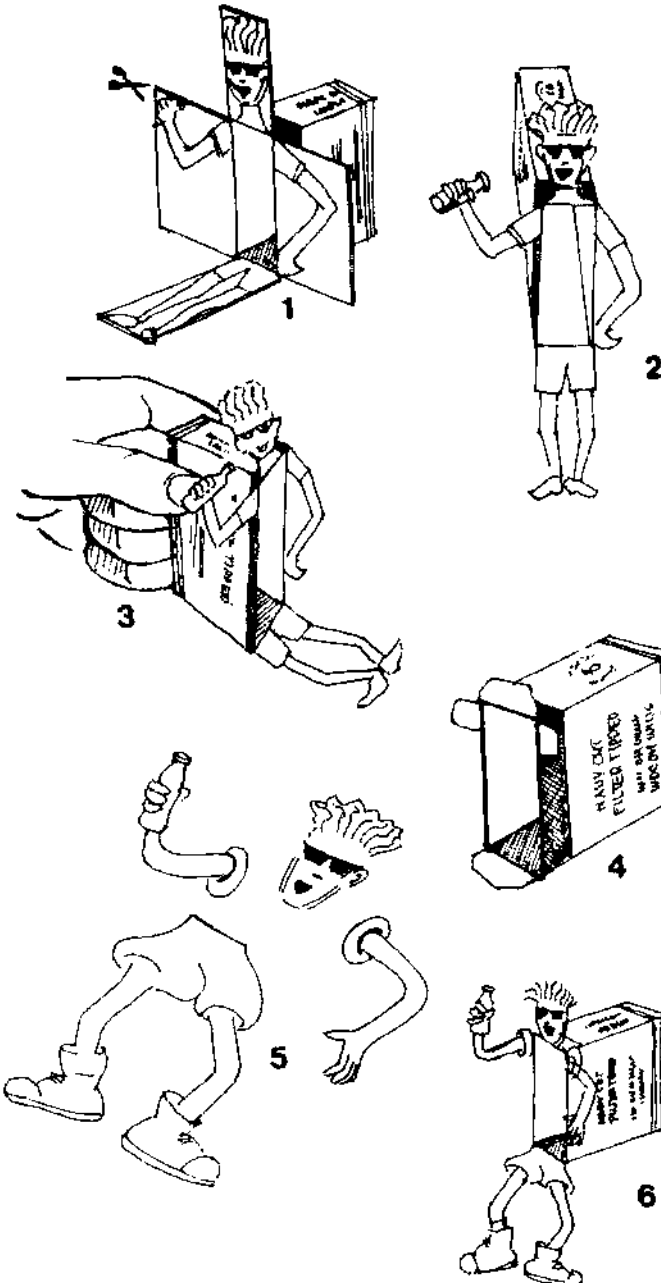

WHICH HAS MORE AREA?

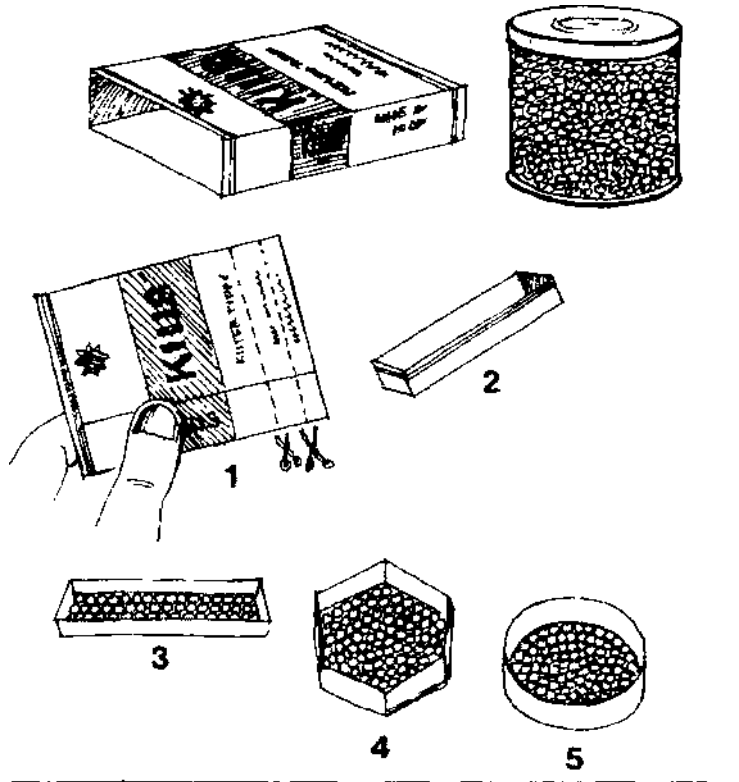

Flatten the outer shell of a cigarette packet and cut three strips, each 1-cm in width (Fig 1).

The strips will have a rectangular box-like shape (Fig 2).

They can be easily creased to make a rectangular box (Fig 3), or hexagonal box (Fig 4), and rolled between two fingers to make a circular hoop (Fig 5).

Fill the rectangular, hexagonal and circular boxes with one layer of dry pea seeds. Count the number of peas in each box. The number of peas will indicate the area of each box.

As all the boxes are shaped from similar strips, they all have the same perimeter.

Why are their areas different?

Which box has the largest area?

You will discover that for the same perimeter the circle encloses the maximum area.

WHICH HOLDS MORE?

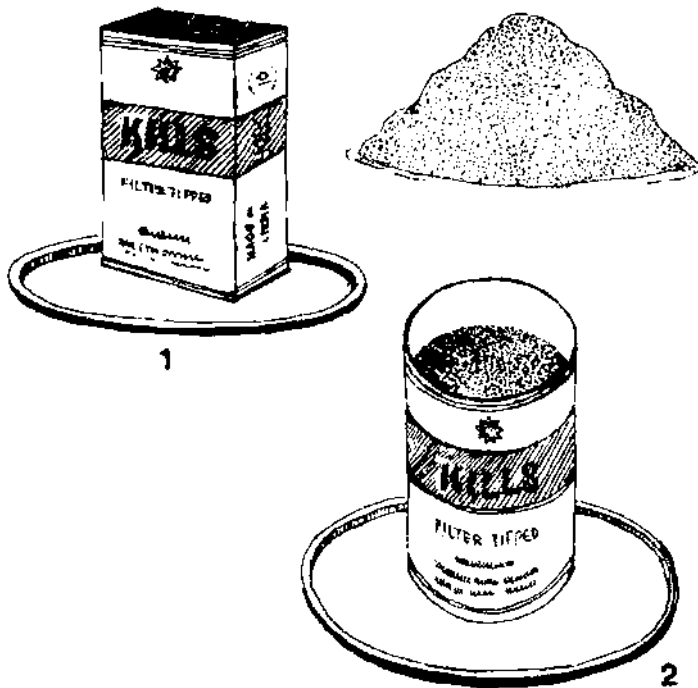

Stand an empty cigarette packet on a lid or a plate.

Fill its rectangular cavity completely with sand (Fig 1).

Now gently press the box from all sides to make its cross-section circular, without letting any of the sand fall.

You will notice that in the circular box the level of the sand drops by almost 20 per cent (Fig 2).

In other words, if we take two boxes with the same perimeter, then the cylindrical box will have 20 per cent more capacity as compared to a rectangular box.

MERRY GO-ROUND

Sanjay Kapur, a student of class eleven, designed this lovely toy.

To make this all you need is the outer case of a cigarette packet, a toothpick, an old refill, an eraser, glue and scissors.

Open out a cigarette packet case and cut along the two dotted lines (Fig 1).

The round- about has a star-shaped thimble at the top and a net square at the base.

These are joined together by four pillars.

The big piece in Fig 2 will form the top star and the square base.

The four pillars will come from the small piece.

Cut square A as shown in Fig 3.

Valley-fold its diagonals and mountain-fold its midlines (Fig 4) so as to form a thimble-like star (Fig 5).

Cut a smaller square B from the remaining portion of Fig 3.

Apply glue on its four-corners and make a small hole in its middle (Fig 6).

Mark out the midlines of the small rectangular piece (Fig 2) and cut along them (Fig 7), to get four small rectangles (Fig 8).

Fold a 3-mm upright leg in these rectangles and apply glue (Fig 9).

Stick with glue the straight ends of these rectangular pillars to the star-shaped thimble, such that the upright legs are in the same orientation (Fig 10).

Glue the legs to the corner of the square base to complete the rotating part (Fig 11).

Poke an eraser with a divider point and fur a toothpick in it.

Stick the eraser at one end of the cigarette packet.

Fold this pack along the dotted lines and stick an empty refill for blowing (Fig 12).

Place the roundabout on the toothpick and blow through the refill.

The air will strike the vertical pillars and make the merry-go-round whirl (Fig 13).

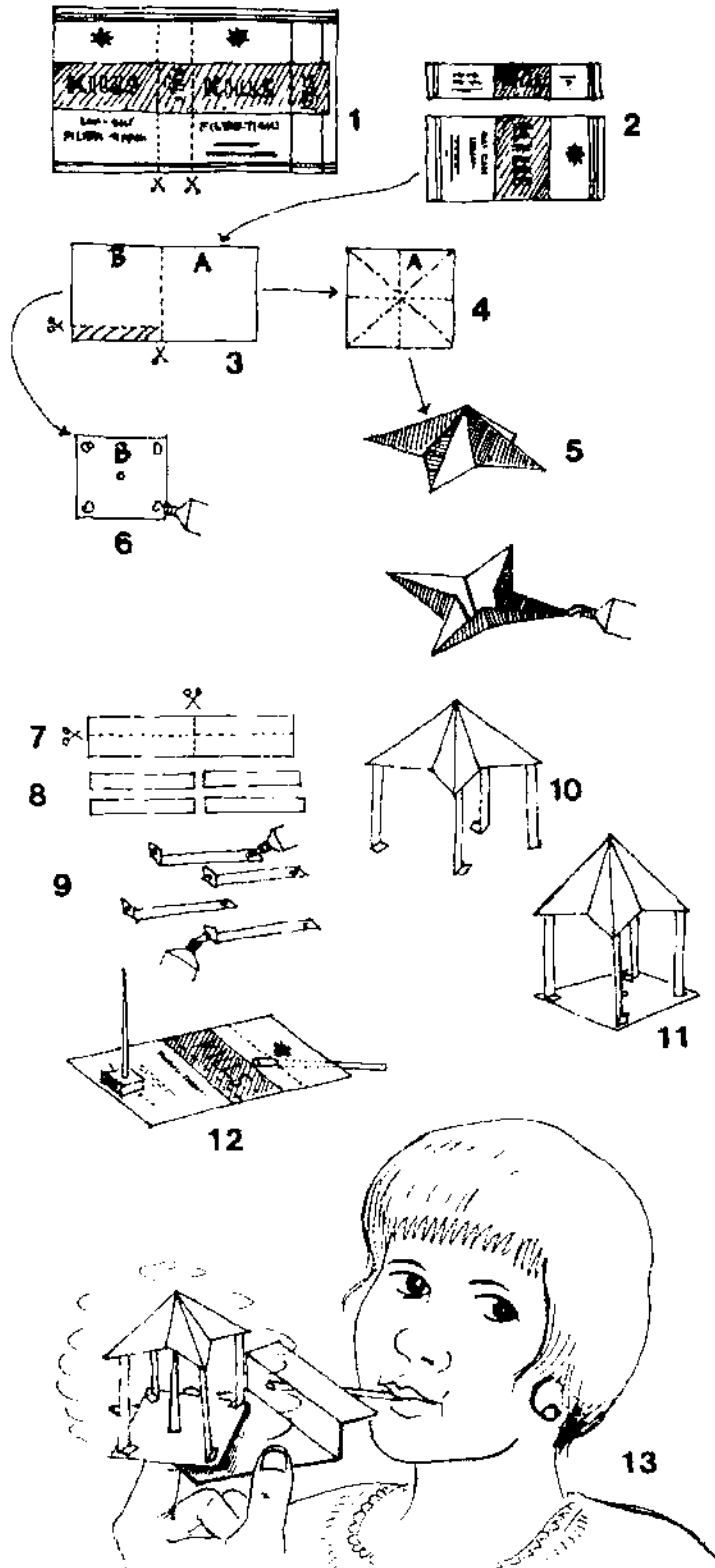

MOUTH ORGAN

Sri Najeeb, an activist of the Kerala Shastra Sahitya Parishad (KSSP), first showed this toy to me.

It is a simple mouth organ made from an old cigarette packet.

First remove the drawer of the cigarette packet as shown in Fig 1.

Fold it midway along the length and cut out an arc as shown in Fig 2.

Crease the midline of the sidewall so that they cave in, making a V-groove (Fig 3).

Tuck both ends of the drawer into the case as shown in Fig 4.

Now fold the outer case in the middle so that the two strips of the drawer almost meet with a very thin gap between them (Fig 5).

Place the organ gently between your lips and blow into it. You will hear a musical note (Fig 6).

This toy is based on Bernoulli's principle, according to which when air blows at high speed between the two stripes, it creates a low-pressure zone and makes the strips vibrate.

This in turn produces the sound.

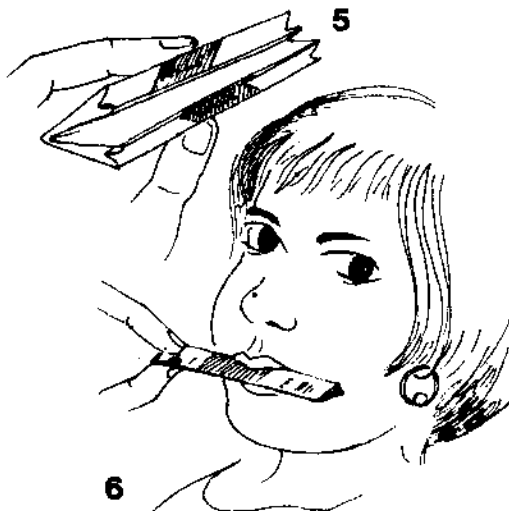
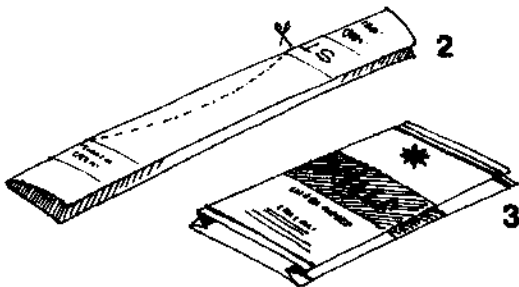
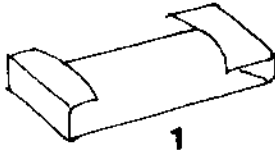

6

MATCHBOX MAZE

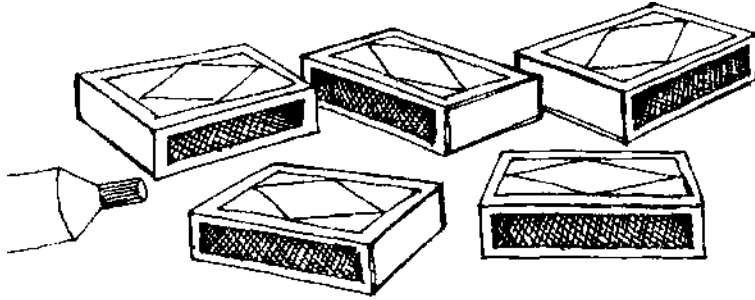

The easy availability of matchboxes has made them staple objects for satisfying scientific and mathematical curiosity.

The puzzle shown in the Figure was made by using five empty matchboxes.

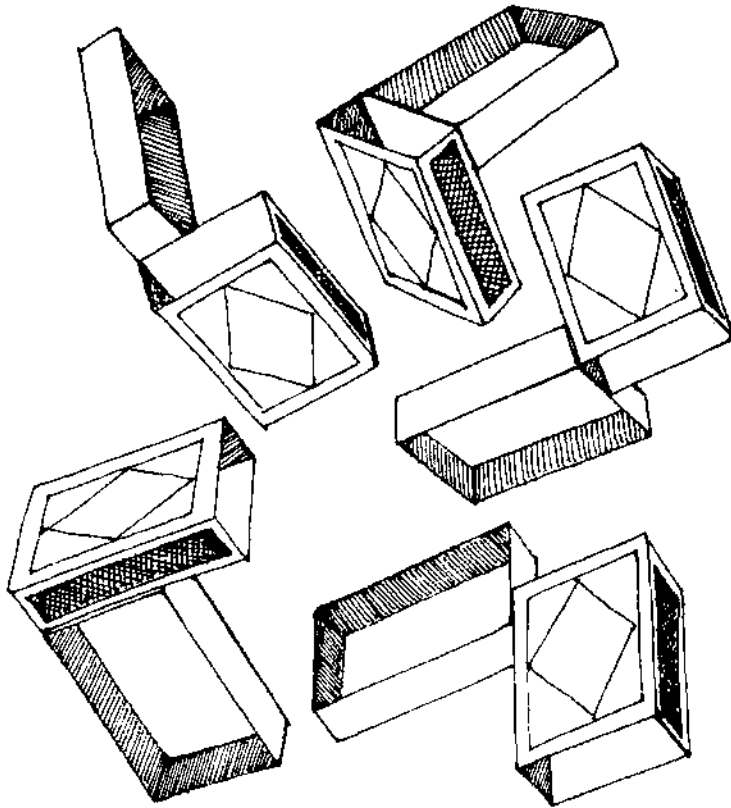

This unusual puzzle, designed by a scientist named Van Deventer, has five inside drawers of the matchboxes stuck to their outer cases in different positions.

The ideal matchbox size for the puzzle should be such that its three dimensions are in the ratio 1: 2: 3.

However, the ordinary “*Ship*” brand matchboxes available in our country will serve our purpose reasonably well.

Glue the five drawers to their respective cases.

You now have to figure out how the drawer of one case slides into the shell of the other.

If you are on the right track then the entire assembly will simply fall into place with no need to push and pull.

One such complete assembly is shown in the last illustration.

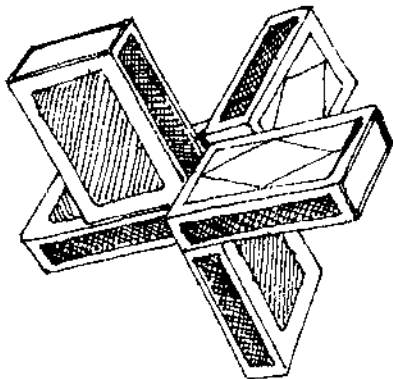

According to Van Deventer, there are three distinct ways in which the five matchboxes can be put together.

First try assembling them in the orientation given already.

Can you figure out the other two ways?

CATCH A BUTTERFLY

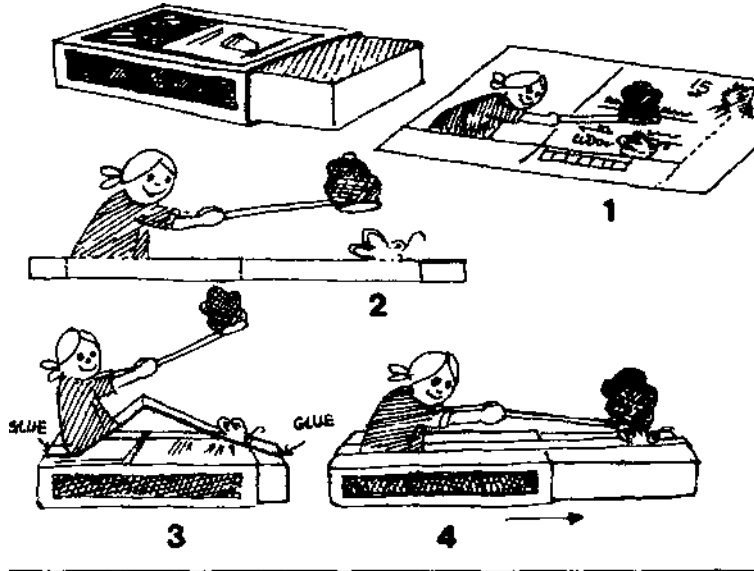

This dynamic toy requires an old postcard and an empty matchbox. First draw the picture of the girl and the butterfly on a postcard (Fig 1), and then cut it.

Fold the picture along the five dotted lines (Fig 2).

Stick one end of the post-card strip to the matchbox base and the other end to the matchbox drawer (Fig 3).

In this position the girl's hand will be at an upward inclination and the net will be far removed from the butterfly.

On pulling the matchbox drawer outwards (Fig 4), the girl catches the butterfly in the net.

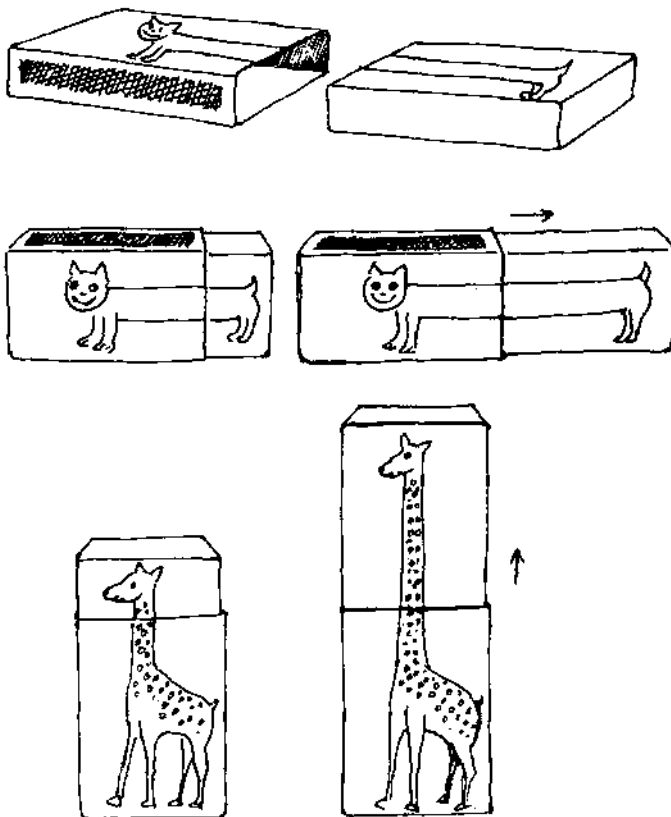

STRETCHABLE STOMACH

This toy is a source of amusement for little children.

Paste a white paper on the outer case of a matchbox as also on its drawer.

Draw a cat as shown.

When the drawer is slid inside, the cat appears its normal size.

On pulling the drawer out, it appears as if the cat has a stretchable stomach.

In another variation of this toy, the neck of a giraffe can be stretched, much to the amusement of children!

SIMPLE SPINNER

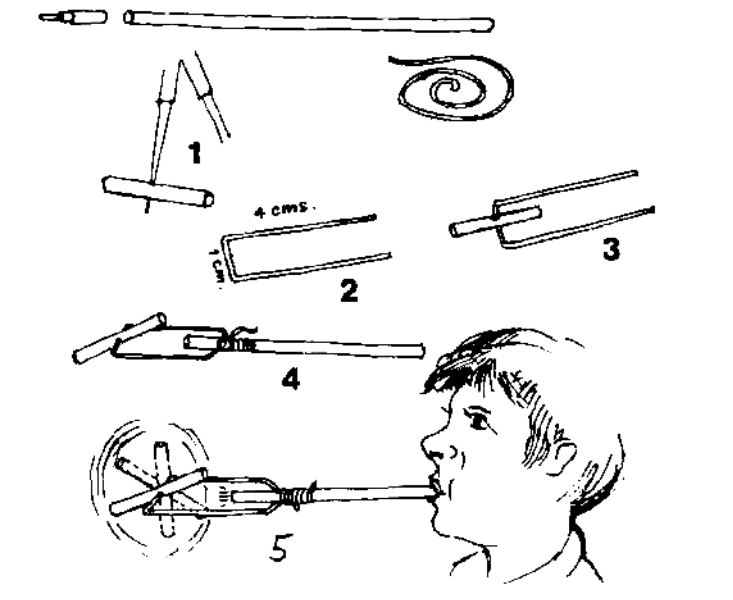

Cut a 2-cm long piece from an old ball-pen refill and make a hole in its center with a divider point (Fig 1).

Take a thin wire of length 9-cm and fold it into a U-shape (Fig 2).

Weave the refill spinner in the U-shaped wire (Fig 3).

Wrap the two ends of the wire on the plastic refill, leaving enough clearance for the spinner to rotate (Fig 4).

On blowing through the refill, the spinner rotates (Fig 5).

For obtaining maximum speed - adjust the wires so that air is directed towards the ends of the spinner.

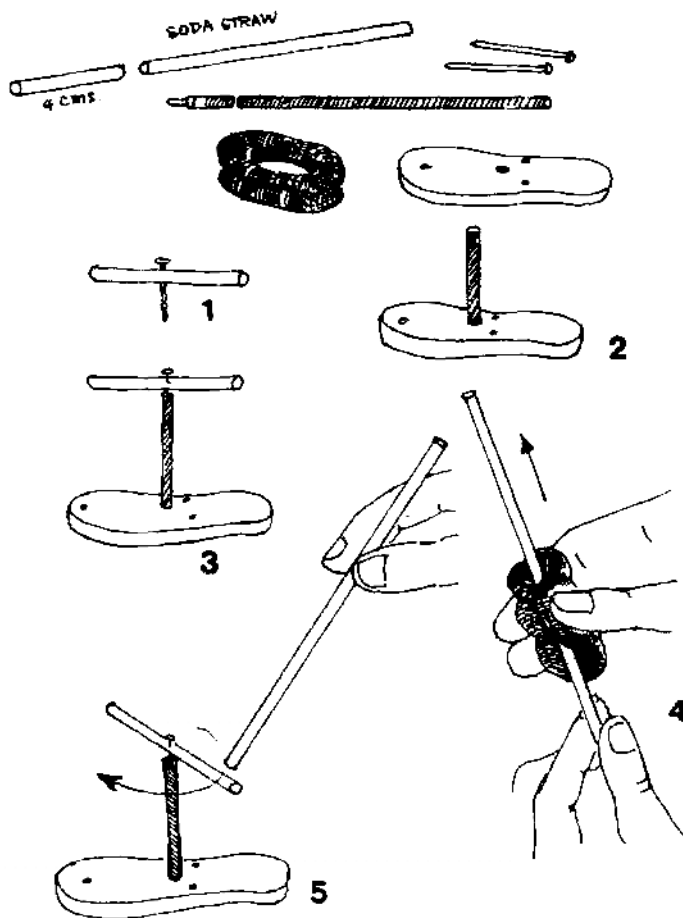

MAGIC WAND

Cut a 4-cm long plastic soda-straw and insert a pin through its center (Fig 1).

Make a hole in an old rubber slipper and insert an empty ball- pen refill in it (Fig 2).

Rub the straw (Fig 1) with a piece of wool or a hair-band and then place the pin in the refill (Fig 3).

Take a long soda-straw and rub it with wool or the hair- band (Fig 4).

Now, as you bring the long straw near the small one, it turns (Fig 5).

Like a magic wand you can keep turning the little straw without ever touching it with the long straw. When the plastic straw is rubbed with wool, some electrons in the straw get knocked off and the straw acquires an electrical charge. When the two straws with the same electric charge are brought close together, they repel each other.

STANDING A STICK

Your ability to balance a stick on your finger depends on the length of the stick, which you can verify by trying sticks of different lengths.

It is easy to balance a meter stick, but difficult to balance a foot ruler, and simply impossible to balance a pencil.

If a long and a short stick are made to stand on a table then the longer stick takes longer time to topple over.

Long sticks have a smaller angular acceleration, and are thus easier to balance than short ones.

However, if a clay ball is fixed to the top end of a stick, it gets easily balanced.

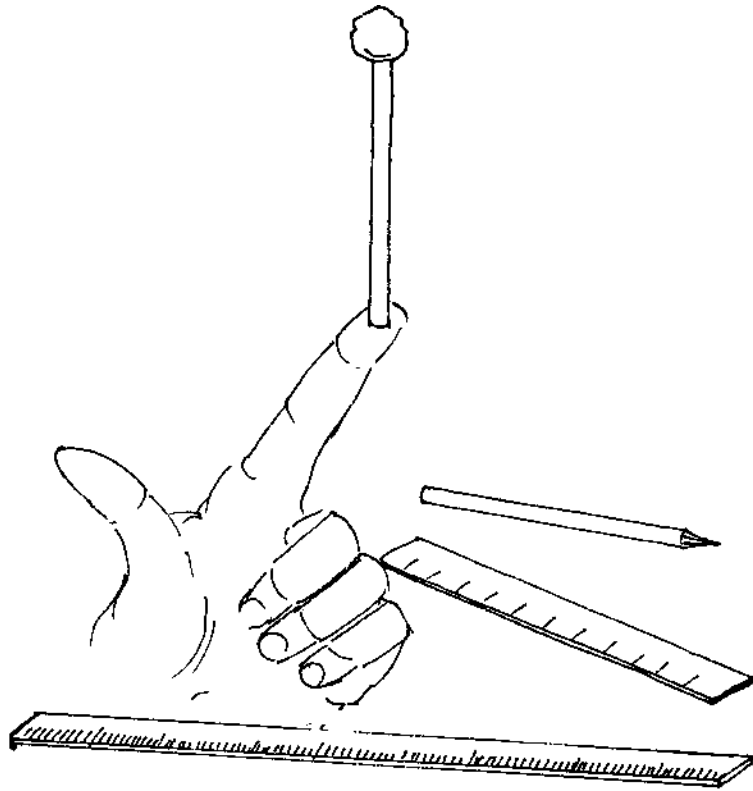

SHELL STRENGTH

Raw eggs can be thrown with full force on a bed sheet without breaking.

This very graphic demonstration illustrates that firstly, eggs are sturdier than you think and secondly, according to Newton's second law, the force on them is not large enough so long as they are not brought to rest too abruptly.

Let two children hold the sheet with the bottom part folded upwards to catch the eggs after they have struck the sheet. Throw the eggs as hard as you can and you will see they do not break.

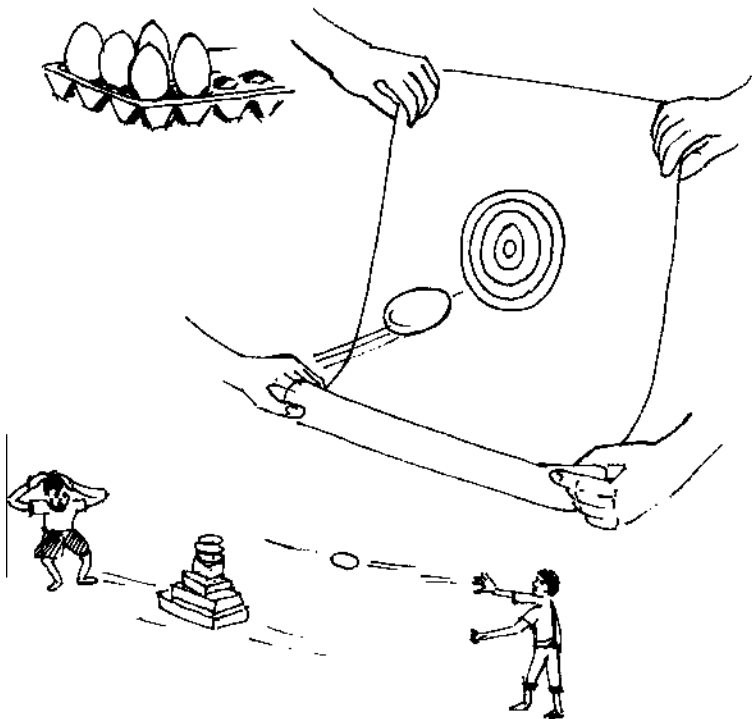

REED STRUCTURES

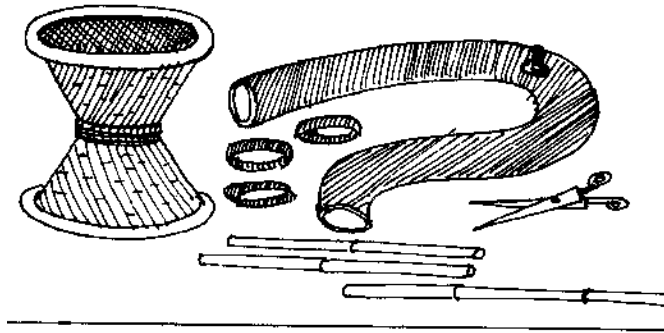

Did you know that reeds used for making stools belong to the same family of plants as sugarcane?

Reeds are natural rods and have been used for making walls, roofs and all kinds of furniture.

Two reeds are joined together by tying an old cycle rubber tube of width 6-mm.

The rubber band can be stretched and tied over.

Finally, the end loop of the rubber tube is slipped over one reed.

Stretched rubber grips a large area of the reed and makes a very firm joint (Fig 1).

Using three reeds and three rubber tubes makes a triangular shape.

This triangular frame is very strong (Fig 2).

Make a square frame by using four reeds.

Try pushing two opposite corners of the square as shown in Fig 3.

You will find that the square is distorted into a kite-shaped rhombus (Fig 4).

If you want the square to remain a square then add a diagonal member to it as shown in Fig 5.

The diagonal divides the square into two triangles, making it rigid. Join six reeds with rubber bands to make a tetrahedron (Fig 6).

As the tetrahedron is made up only of triangles, it is very rigid and strong.

With the help of a friend you can also make the structure of a house by using reeds and cycle-tube joints

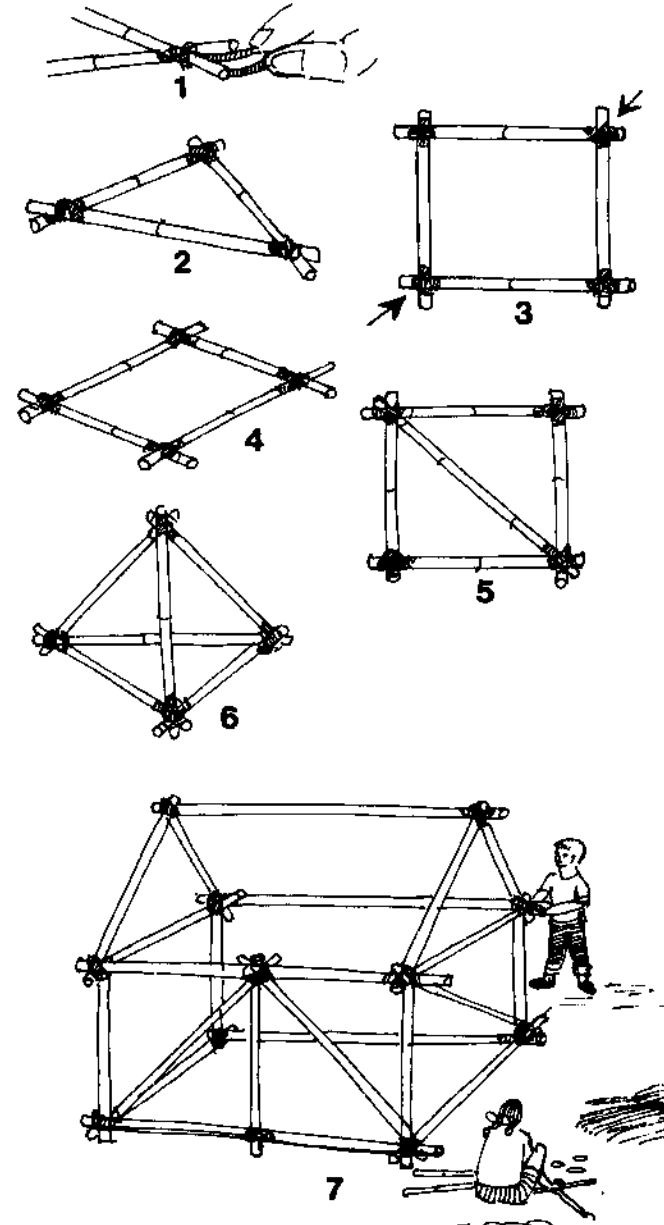

TUMBLING CAPSULE

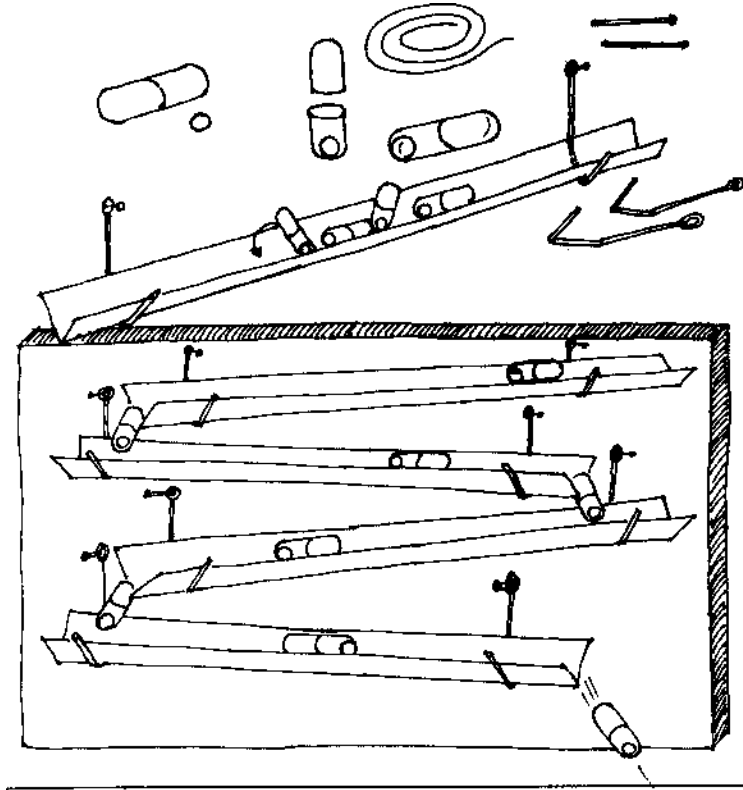

Empty medicine capsules can be used, or else take an old capsule, slide open its two halves and empty out its contents.

Place a cycle steel ball in one half of the capsule and then close its lid.

Fold a long card strip in the middle to form a V-shaped channel.

Place the capsule in the channel.

On tilting the channel, the capsule somersaults and rolls from the higher to the lower level.

Use wire hooks to affix several V-shaped channels on a vertical soft board.

The slopes of the channel should be just enough to make the capsule roll.

On placing the capsule on the high end of the top channel, it rolls down into the second, then the third and finally down the fourth channel.

The track can be made longer by adding more channels.

The capsule tumbles on because of its shifting center of gravity.

Its rolling motion is very intriguing and provides you hours of fun.

CARTESIAN DIVER

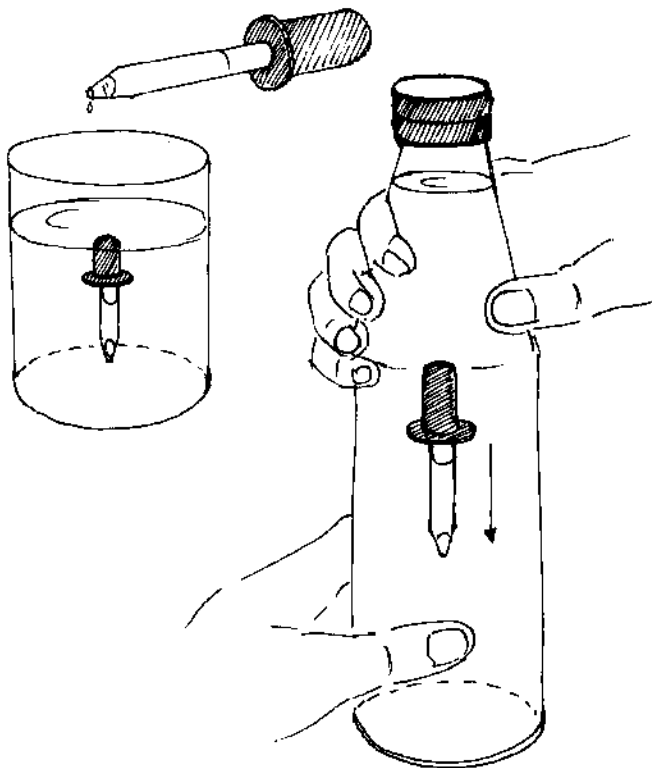

According to Archimedes' principle, a barely floating compressible object in a sealed container can be made to sink by applying a small external pressure to the container.

Take a medicine or ink dropper and fill it with just enough water to make it float in a container of water.

This makes a 'barely buoyant diver'.

Put the diver in a plastic bottle, fill the bottle to the top with water and cap it.

When the bottle is squeezed, the pressure on the diver reduces the diver's volume, causing it to displace a small quantity of water.

The diver slowly sinks to the bottom.

On releasing the pressure, the diver rises.

BAMBOO POPGUN

Take a 30-cm long piece of bamboo with an internal bore of 8-10 mm.

The bamboo should be open at one end and closed at the other (Fig 1).

Cut the bamboo at a distance of 8-cm from its closed end (Fig 2).

Place a 5-mm thick bamboo stick in the bore of the small piece.

Hammer a few thin wedges to secure the bamboo stick in place (Fig 3).

The bamboo stick attached to the handle now becomes the plunger.

How to make the pellets for the popgun?

Dip a piece of newspaper in water.

Tear out a piece of this soggy newspaper and make a little pellet out of it.

Push this pellet into the bamboo bore with the plunger, until it just reaches the other end of the bamboo.

Remove the plunger and place a second newspaper pellet as shown in Fig 4.

Using the plunger push this pellet in with force.

You will be surprised to see the first pellet come out with a loud bang (Fig 5).

When you push the second pellet, the air column between the two pellets gets compressed and pushes the first pellet to come out with a bang, as this happens, the second pellet occupies the position of the first one. This is an illustrious example of an ingenious folk toy.

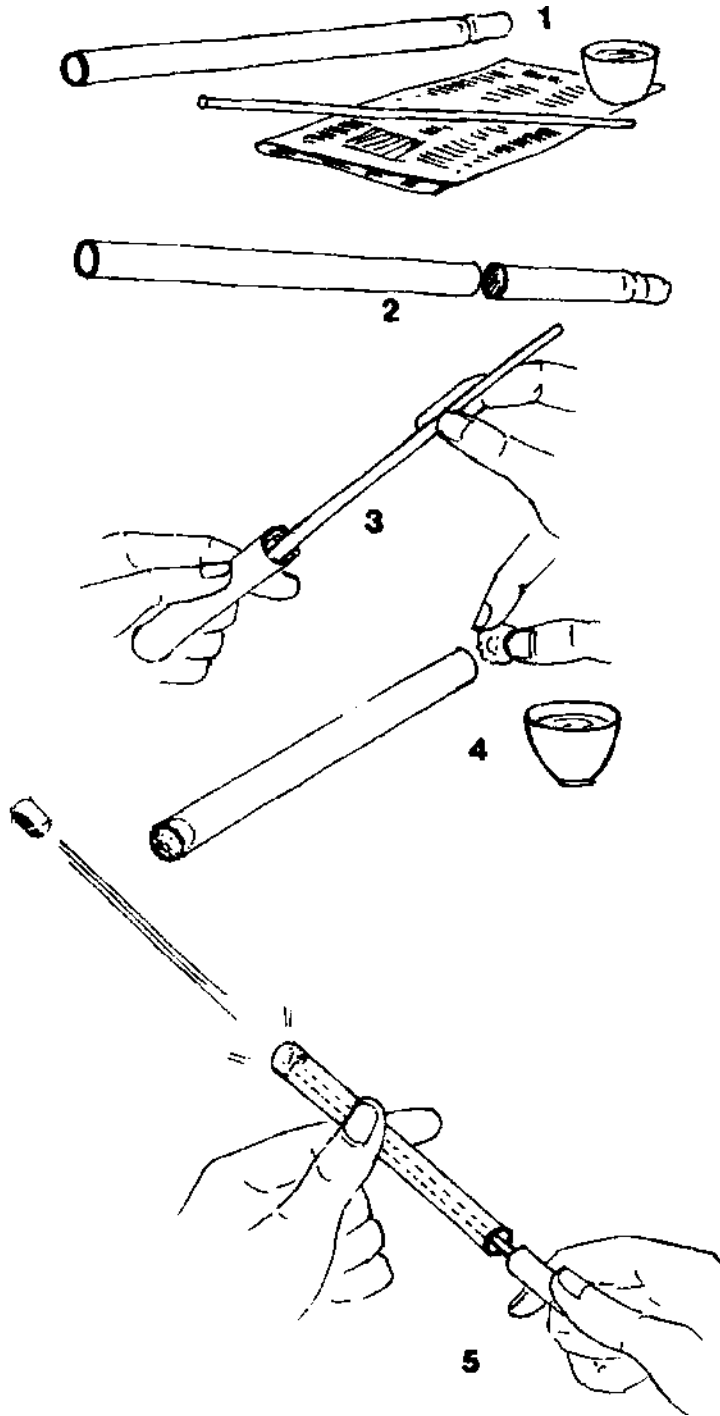

SYRINGE POPGUN

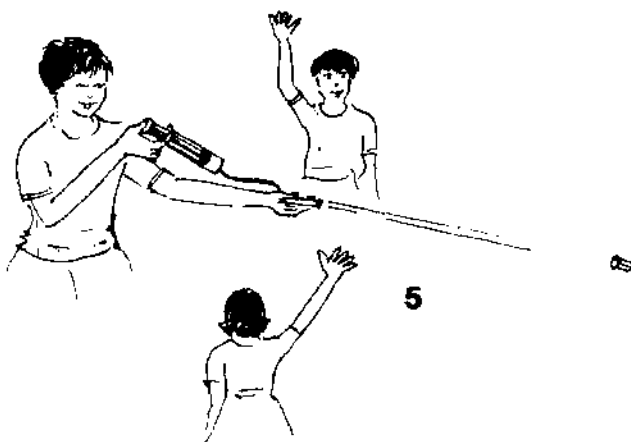
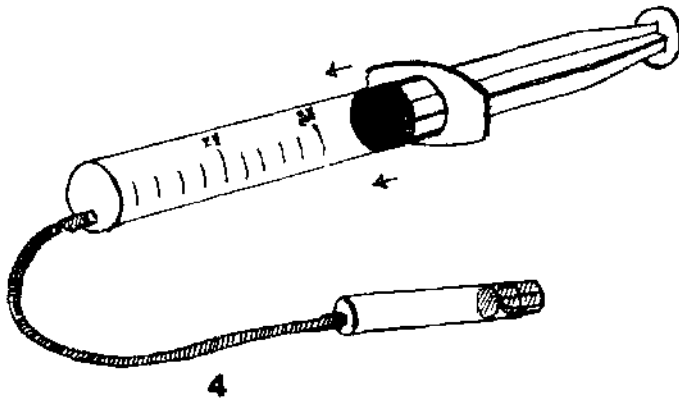
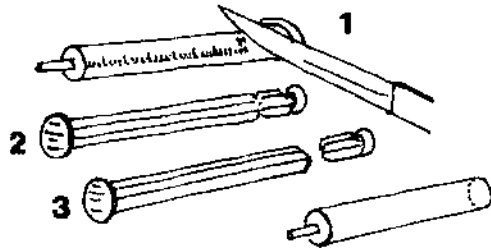
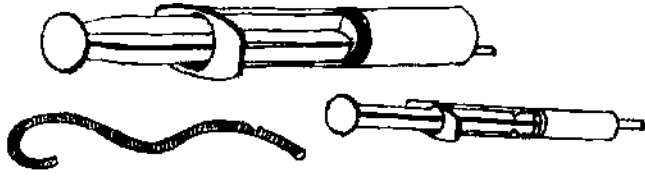

Modern medicine produces a lot of junk, like the disposable plastic syringe for example.

Take a 2.5-ml and a 20-ml plastic syringe. Do not touch their needles as they can cause severe infection.

Wash these plastic syringes well. Cut off 1-cm of the big 2.5-ml syringe (Fig 1).

The plunger of the 2.5-ml syringe has a weak neck located very close to the piston (Fig 2).

Cut along the neck. The piston along with the fluted end makes the bullet (Fig 3).

Connect the outlet parts of the two syringes with a cycle valve tube of length 15-cm.

Pull out the plunger of the big syringe so that it is in its initial position and place the bullet in the small syringe.

The circular end of the syringe should go in first (Fig 4).

Now, if you push in the big plunger quickly, the bullet shoots out from the small syringe with a bang (Fig 5).

This is because the trapped air gets compressed by about ten times and this is enough to eject the bullet with a loud pop.

The bullet travels a distance of 3 to 5 meters. Sanjay Kapur, a student of class eleven, designed this popgun.

It is based on the same principle as the bamboo popgun.

MAGIC FAN

This captivating traditional folk toy could at one time be bought in village fairs. You cannot buy it today but you can make it at home in no time at all.

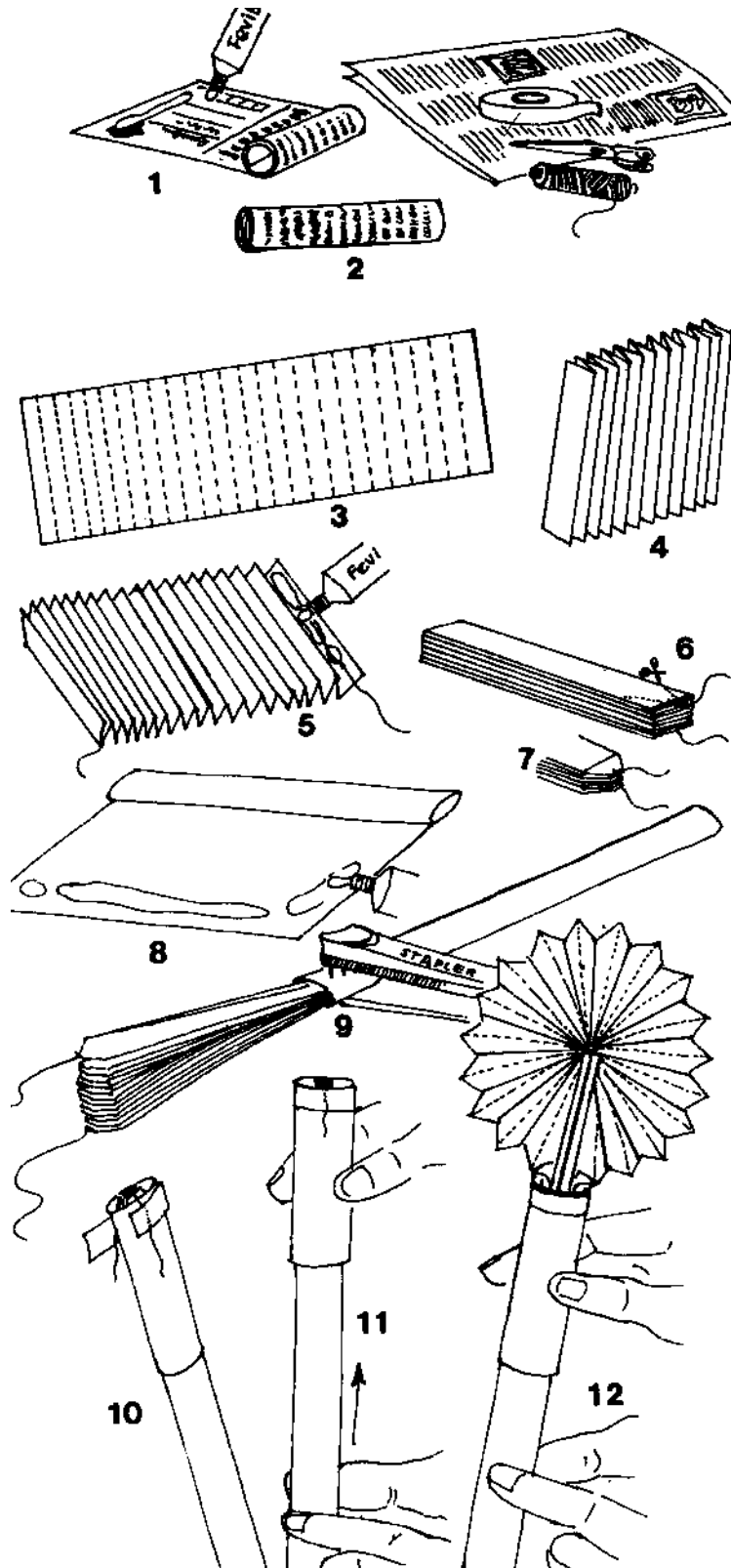

Roll and stick an old postcard to make a cylindrical reel (Fig 1), with a diameter of about 2-cm (Fig 2).

Fold a sheet of glazed newspaper (10-cm x 50-cm) into a fan with 32 creases (Fig 3, 4).

Make sure that all the zigzag creases are of the same width.

Fix a thread each on the two extreme ends of the corrugated fan (Fig 5).

About 5-cm of the thread should be left trailing out.

Trim off the triangular edges of the folded fan as shown (Fig 6, 7).

Cut a square (20-cm x 20-cm) from a newspaper.

Roll it into a hollow stick and glue its edge (Fig B).

Tuck one end of the fan in this hollow stick and staple it (Fig 9).

Slip the postcard reel over the fan.

The top of the reel and the fan should be at the same level, with the free ends of the threads hanging out.

Fix the threads to the postcard reel with cello-tape (Fig 10).

If you now hold the newspaper stick with one hand and slip down the postcard reel with the other (Fig 11), the fan opens out gloriously like the wings of a peacock (Fig 12).

On sliding the reel upwards, the fan pleats fold in and settle snugly inside the reel.

Before creasing the fan you can inscribe a message, such as "HAPPY BIRTHDAY", on it.

The message gets flashed on opening the fan, much to the surprise of your friends!